

ST(意法) LF18CDT-TRY **PDF**

深圳创唯电子有限公司

<http://www.rohm-chip.com>

Very low drop voltage regulator with inhibit function

Datasheet - production data

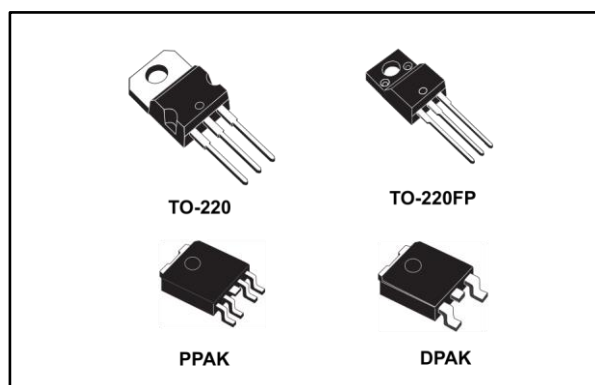

Description

The LFXX is a very low drop regulator available in TO-220, TO-220FP, DPAK and PPAK packages and in a wide range of output voltages. The low drop voltage (0.45 V) and low quiescent current make it particularly suitable for low-noise, low-power applications and especially in battery-powered systems. In the 5 pin configuration (PPAK) a shutdown logic control function is available (pin 2, TTL compatible). This means that when the device is used as a local regulator, a part of the board can be put in standby, decreasing the total power consumption. In the three terminal configuration, the device has the same electrical performance, but it is fixed in ON state. It requires a capacitor of only 2.2 μF for stability, saving board space and costs. The LFXX is available as automotive grade in DPAK and PPAK packages, for the options of output voltages whose commercial part numbers are shown in the order codes. These devices are qualified according to the specification AEC-Q100 of the automotive market, in the temperature range $-40\text{ }^{\circ}\text{C}$ to $125\text{ }^{\circ}\text{C}$, and the statistical tests PAT, SYL, SBL are performed.

Features

- Very low-dropout voltage (0.45 V)
- Very low quiescent current (typ. 50 μA in OFF mode, 500 μA in ON mode)
- Output current up to 500 mA
- Logic-controlled electronic shutdown
- Output voltages of 1.5; 1.8; 2.5; 3.3; 4.7; 5; 6; 8; 8.5; 9; 12 V
- Automotive grade product: 1.8 V, 2.5 V, 3.3 V, 5.0 V, 8.0 V, 8.5 V V_{OUT} in DPAK and PPAK packages
- Internal current and thermal limit
- Only 2.2 μF for stability
- Available in $\pm 1\%$ (AB), $\pm 1.5\%$ (AC) or $\pm 2\%$ (C) selection at $25\text{ }^{\circ}\text{C}$
- Supply voltage rejection: 80 db (typ.)
- Temperature range: from -40 to $125\text{ }^{\circ}\text{C}$

Contents

| | | |
|----------|--|-----------|
| 1 | Diagram | 3 |
| 2 | Pin configuration | 4 |
| 3 | Maximum ratings | 5 |
| 4 | Electrical characteristics | 6 |
| 5 | Typical performance characteristics | 33 |
| 6 | Package information | 38 |
| 6.1 | TO-220 (dual gauge) package information..... | 38 |
| 6.2 | TO-220 (single gauge) package information | 40 |
| 6.3 | TO-220FP package information | 42 |
| 6.4 | TO-220 packing information | 44 |
| 6.5 | DPAK package information | 45 |
| 6.6 | PPAK package information | 47 |
| 6.7 | PPAK and DPAK packing information..... | 49 |
| 7 | Ordering information | 51 |
| 8 | Revision history | 52 |

1 Diagram

Figure 1: Block diagram

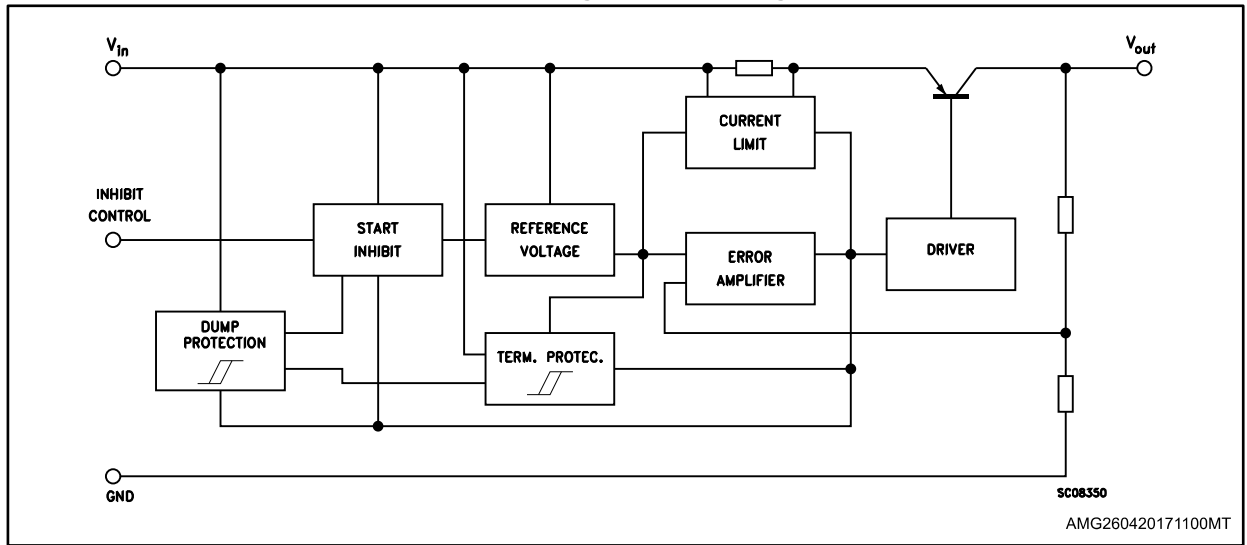

2 Pin configuration

Figure 2: Pin connections (top view)

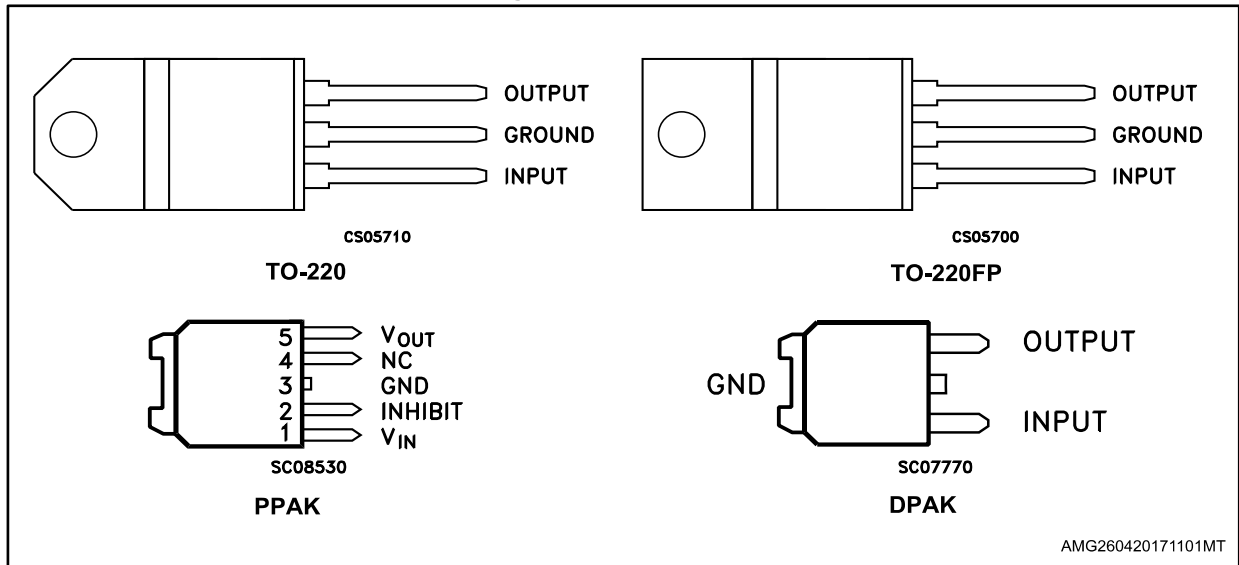

TAB is electrically connected to GND on TO-220, PPAK and DPAK packages.

3 Maximum ratings

Table 1: Absolute maximum ratings

| Symbol | Parameter | Value | Unit |
|-----------|--------------------------------------|---------------------------|------|
| V_I | DC input voltage | -0.5 to 40 ⁽¹⁾ | V |
| I_O | Output current | Internally limited | A |
| P_{TOT} | Power dissipation | Internally limited | W |
| T_{STG} | Storage temperature range | -40 to 150 | °C |
| T_{OP} | Operating junction temperature range | -40 to 125 | °C |

Notes:

⁽¹⁾For $18 < V_I < 40$ the regulator is in shutdown.

Table 2: Thermal data

| Symbol | Parameter | TO-220 | TO-220FP | DPAK/PPAK | Unit |
|------------|-------------------------------------|--------|----------|-----------|------|
| R_{thJC} | Thermal resistance junction-case | 5 | 5 | 8 | °C/W |
| R_{thJA} | Thermal resistance junction-ambient | 50 | 60 | 100 | °C/W |

Figure 3: Test circuit

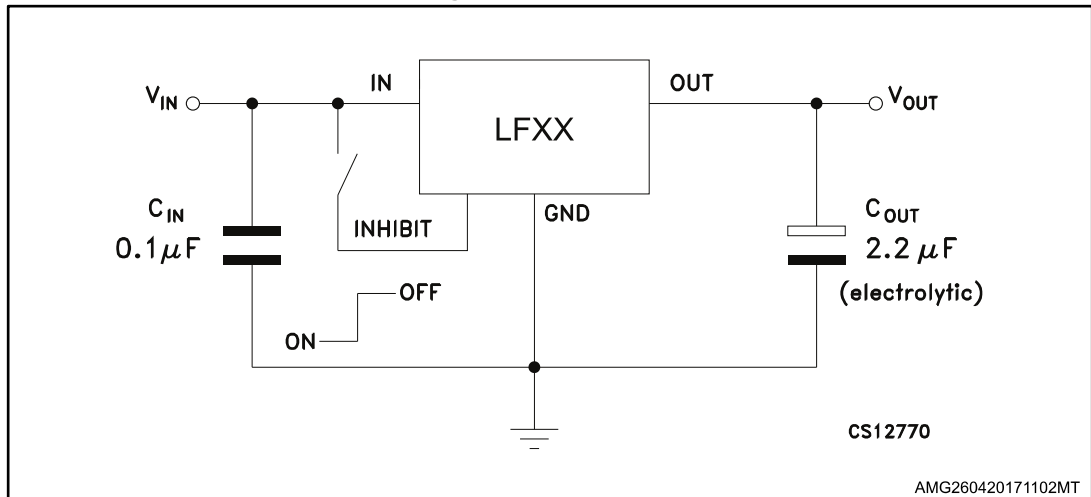

4 Electrical characteristics

Refer to test circuits, $T_J = 25\text{ °C}$, $C_I = 0.1\text{ }\mu\text{F}$, $C_O = 2.2\text{ }\mu\text{F}$ unless otherwise specified.

Table 3: LF15AB electrical characteristics

| Symbol | Parameter | Test condition | Min. | Typ. | Max. | Unit |
|--------------|---------------------------|--|---------------------|------|-------|---------------|
| V_O | Output voltage | $I_O = 50\text{ mA}$ $V_I = 3.5\text{ V}$ | 1.485 | 1.5 | 1.515 | V |
| | | $I_O = 50\text{ mA}$ $V_I = 3.5\text{ V}$ $T_a = -25\text{ to }85\text{ °C}$ | 1.470 | | 1.530 | |
| V_I | Operating input voltage | $I_O = 500\text{ mA}$ | 2.5 | | 16 | V |
| I_O | Output current limit | | | 1 | | A |
| ΔV_O | Line regulation | $V_I = 2.5\text{ to }16\text{ V}$ $I_O = 5\text{ mA}$ | | 2 | 10 | mV |
| ΔV_O | Load regulation | $V_I = 2.8\text{ V}$ $I_O = 5\text{ to }500\text{ mA}$ | | 2 | 10 | mV |
| I_d | Quiescent current | $V_I = 2.5\text{ to }16\text{ V}$ $I_O = 0\text{ mA}$ | ON mode | 0.5 | 1 | mA |
| | | $V_I = 2.8\text{ to }16\text{ V}$ $I_O = 500\text{ mA}$ | | | | |
| | | $V_I = 6\text{ V}$ | OFF mode | 50 | 100 | μA |
| SVR | Supply voltage rejection | $I_O = 5\text{ mA}$ $V_I = 3.5 \pm 1\text{ V}$ | $f = 120\text{ Hz}$ | 82 | | dB |
| | | | $f = 1\text{ kHz}$ | 77 | | |
| | | | $f = 10\text{ kHz}$ | 65 | | |
| eN | Output noise voltage | $B = 10\text{ Hz to }100\text{ kHz}$ | | 50 | | μV |
| V_d | Dropout voltage | $I_O = 200\text{ mA}$ | | 1 | | V |
| V_{IL} | Control input logic low | $T_a = -40\text{ to }125\text{ °C}$ | | | 0.8 | V |
| V_{IH} | Control input logic high | $T_a = -40\text{ to }125\text{ °C}$ | 2 | | | V |
| I_I | Control input current | $V_I = 6\text{ V}$ $V_C = 6\text{ V}$ | | 10 | | μA |
| C_O | Output bypass capacitance | ESR = 0.1 to 10 Ω $I_O = 0\text{ to }500\text{ mA}$ | 2 | 10 | | μF |

Refer to test circuits, $T_J = 25\text{ °C}$, $C_I = 0.1\text{ }\mu\text{F}$, $C_O = 2.2\text{ }\mu\text{F}$ unless otherwise specified.

Table 4: LF18AB electrical characteristics

| Symbol | Parameter | Test condition | Min. | Typ. | Max. | Unit |
|--------------|---------------------------|--|---------------------|------|-------|---------------|
| V_O | Output voltage | $I_O = 50\text{ mA}$ $V_I = 3.3\text{ V}$ | 1.782 | 1.8 | 1.818 | V |
| | | $I_O = 50\text{ mA}$ $V_I = 3.3\text{ V}$ $T_a = -25\text{ to }85\text{ °C}$ | 1.764 | | 1.836 | |
| V_I | Operating input voltage | $I_O = 500\text{ mA}$ | 3 | | 16 | V |
| I_O | Output current limit | | | 1 | | A |
| ΔV_O | Line regulation | $V_I = 2.8\text{ to }16\text{ V}$ $I_O = 5\text{ mA}$ | | 2 | 12 | mV |
| ΔV_O | Load regulation | $V_I = 3.3\text{ V}$ $I_O = 5\text{ to }500\text{ mA}$ | | 2 | 10 | mV |
| I_d | Quiescent current | $V_I = 2.5\text{ to }16\text{ V}$ $I_O = 0\text{ mA}$ | ON mode | 0.5 | 1 | mA |
| | | $V_I = 3.1\text{ to }16\text{ V}$ $I_O = 500\text{ mA}$ | | | | |
| | | $V_I = 6\text{ V}$ | OFF mode | 50 | 100 | μA |
| SVR | Supply voltage rejection | $I_O = 5\text{ mA}$ $V_I = 3.5 \pm 1\text{ V}$ | $f = 120\text{ Hz}$ | 82 | | dB |
| | | | $f = 1\text{ kHz}$ | 77 | | |
| | | | $f = 10\text{ kHz}$ | 60 | | |
| eN | Output noise voltage | $B = 10\text{ Hz to }100\text{ kHz}$ | | 50 | | μV |
| V_d | Dropout voltage | $I_O = 200\text{ mA}$ | | 0.7 | | V |
| V_{IL} | Control input logic low | $T_a = -40\text{ to }125\text{ °C}$ | | | 0.8 | V |
| V_{IH} | Control input logic high | $T_a = -40\text{ to }125\text{ °C}$ | 2 | | | V |
| I_I | Control input current | $V_I = 6\text{ V}$ $V_C = 6\text{ V}$ | | 10 | | μA |
| C_O | Output bypass capacitance | ESR = 0.1 to 10 Ω $I_O = 0\text{ to }500\text{ mA}$ | 2 | 10 | | μF |

Refer to test circuits, $T_J = 25\text{ }^\circ\text{C}$, $C_I = 0.1\text{ }\mu\text{F}$, $C_O = 2.2\text{ }\mu\text{F}$ unless otherwise specified.

Table 5: LF18C electrical characteristics

| Symbol | Parameter | Test condition | Min. | Typ. | Max. | Unit | |
|--------------|---------------------------|--|---------------------|------|-------|---------------|---------------|
| V_O | Output voltage | $I_O = 50\text{ mA}$ $V_I = 3.5\text{ V}$ | 1.764 | 1.8 | 1.836 | V | |
| | | $I_O = 50\text{ mA}$ $V_I = 3.5\text{ V}$ $T_a = -25\text{ to }85\text{ }^\circ\text{C}$ | 1.728 | | 1.872 | | |
| V_I | Operating input voltage | $I_O = 500\text{ mA}$ | 3 | | 16 | V | |
| I_O | Output current limit | | | 1 | | A | |
| ΔV_O | Line regulation | $V_I = 2.8\text{ to }16\text{ V}$ $I_O = 5\text{ mA}$ | | 2 | 12 | mV | |
| ΔV_O | Load regulation | $V_I = 3.3\text{ V}$ $I_O = 5\text{ to }500\text{ mA}$ | | 2 | 10 | mV | |
| I_d | Quiescent current | $V_I = 2.5\text{ to }16\text{ V}$ $I_O = 0\text{ mA}$ | ON mode | | 0.5 | 1 | mA |
| | | $V_I = 3.1\text{ to }16\text{ V}$ $I_O = 500\text{ mA}$ | | | | 12 | |
| | | $V_I = 6\text{ V}$ | OFF mode | | 50 | 100 | μA |
| SVR | Supply voltage rejection | $I_O = 5\text{ mA}$ $V_I = 3.5 \pm 1\text{ V}$ | $f = 120\text{ Hz}$ | | 82 | dB | |
| | | | $f = 1\text{ kHz}$ | | 77 | | |
| | | | $f = 10\text{ kHz}$ | | 60 | | |
| eN | Output noise voltage | $B = 10\text{ Hz to }100\text{ kHz}$ | | 50 | | μV | |
| V_d | Dropout voltage | $I_O = 200\text{ mA}$ | | 0.7 | | V | |
| V_{IL} | Control input logic low | $T_a = -40\text{ to }125\text{ }^\circ\text{C}$ | | | 0.8 | V | |
| V_{IH} | Control input logic high | $T_a = -40\text{ to }125\text{ }^\circ\text{C}$ | 2 | | | V | |
| I_I | Control input current | $V_I = 6\text{ V}$ $V_C = 6\text{ V}$ | | 10 | | μA | |
| C_O | Output bypass capacitance | ESR = 0.1 to 10 Ω $I_O = 0\text{ to }500\text{ mA}$ | 2 | 10 | | μF | |

Refer to test circuits, $T_a = -40$ to 125 °C, $C_i = 0.1$ μ F, $C_o = 2.2$ μ F unless otherwise specified.

Table 6: LF18C (automotive grade) electrical characteristics

| Symbol | Parameter | Test condition | Min. | Typ. | Max. | Unit |
|--------------|---------------------------|---|--------------|------|-------|---------|
| V_o | Output voltage | $I_o = 50$ mA $V_i = 3.5$ V $T_a = 25$ °C | 1.764 | 1.8 | 1.836 | V |
| | | $I_o = 50$ mA $V_i = 3.5$ V | 1.713 | | 1.887 | |
| V_i | Operating input voltage | $I_o = 500$ mA | 3 | | 16 | V |
| I_o | Output current limit | $T_a = 25$ °C | | 1 | | A |
| ΔV_o | Line regulation | $V_i = 2.8$ to 16 V $I_o = 5$ mA | | 2 | 15 | mV |
| ΔV_o | Load regulation | $V_i = 3.3$ V $I_o = 5$ to 500 mA | | 2 | 15 | mV |
| I_d | Quiescent current | $V_i = 2.5$ to 16 V $I_o = 0$ mA | ON mode | 0.5 | 2 | mA |
| | | $V_i = 3.1$ to 16 V $I_o = 500$ mA | | | 12 | |
| | | $V_i = 6$ V | OFF mode | | 50 | 120 |
| SVR | Supply voltage rejection | $I_o = 5$ mA $V_i = 3.5 \pm 1$ V $T_a = 25$ °C | $f = 120$ Hz | | 82 | dB |
| | | | $f = 1$ kHz | | 77 | |
| | | | $f = 10$ kHz | | 60 | |
| eN | Output noise voltage | $B = 10$ Hz to 100 kHz $T_a = 25$ °C | | 50 | | μ V |
| V_d | Dropout voltage | $I_o = 200$ mA | | 0.2 | 1.3 | V |
| | | $I_o = 500$ mA | | 0.4 | 1.3 | |
| V_{IL} | Control input logic low | | | | 0.8 | V |
| V_{IH} | Control input logic high | | 2 | | | V |
| I_i | Control input current | $V_i = 6$ V $V_c = 6$ V $T_a = 25$ °C | | 10 | | μ A |
| C_o | Output bypass capacitance | ESR = 0.1 to 10 Ω $I_o = 0$ to 500 mA | 2 | 10 | | μ F |

Refer to test circuits, $T_J = 25\text{ }^\circ\text{C}$, $C_I = 0.1\text{ }\mu\text{F}$, $C_O = 2.2\text{ }\mu\text{F}$ unless otherwise specified.

Table 7: LF25AB electrical characteristics

| Symbol | Parameter | Test condition | Min. | Typ. | Max. | Unit | |
|--------------|---------------------------|--|---------------------|------|-------|---------------|---------------|
| V_O | Output voltage | $I_O = 50\text{ mA}$ $V_I = 4.5\text{ V}$ | 2.475 | 2.5 | 2.525 | V | |
| | | $I_O = 50\text{ mA}$ $V_I = 4.5\text{ V}$ $T_a = -25\text{ to }85\text{ }^\circ\text{C}$ | 2.450 | | 2.550 | | |
| V_I | Operating input voltage | $I_O = 500\text{ mA}$ | | | 16 | V | |
| I_O | Output current limit | | | 1 | | A | |
| ΔV_O | Line regulation | $V_I = 3.5\text{ to }16\text{ V}$ $I_O = 5\text{ mA}$ | | 2 | 12 | mV | |
| ΔV_O | Load regulation | $V_I = 3.8\text{ V}$ $I_O = 5\text{ to }500\text{ mA}$ | | 2 | 12 | mV | |
| I_d | Quiescent current | $V_I = 3.5\text{ to }16\text{ V}$ $I_O = 0\text{ mA}$ | ON mode | | 0.5 | 1 | mA |
| | | $V_I = 3.8\text{ to }16\text{ V}$ $I_O = 500\text{ mA}$ | | | | 12 | |
| | | $V_I = 6\text{ V}$ | OFF mode | | 50 | 100 | μA |
| SVR | Supply voltage rejection | $I_O = 5\text{ mA}$ $V_I = 4.5 \pm 1\text{ V}$ | $f = 120\text{ Hz}$ | | 82 | | dB |
| | | | $f = 1\text{ kHz}$ | | 77 | | |
| | | | $f = 10\text{ kHz}$ | | 65 | | |
| eN | Output noise voltage | $B = 10\text{ Hz to }100\text{ kHz}$ | | 50 | | μV | |
| V_d | Dropout voltage | $I_O = 200\text{ mA}$ | | 0.2 | 0.35 | V | |
| | | $I_O = 500\text{ mA}$ | | 0.4 | 0.7 | | |
| V_{IL} | Control input logic low | $T_a = -40\text{ to }125\text{ }^\circ\text{C}$ | | | 0.8 | V | |
| V_{IH} | Control input logic high | $T_a = -40\text{ to }125\text{ }^\circ\text{C}$ | 2 | | | V | |
| I_i | Control input current | $V_I = 6\text{ V}$ $V_C = 6\text{ V}$ | | 10 | | μA | |
| C_O | Output bypass capacitance | ESR = 0.1 to 10 Ω $I_O = 0\text{ to }500\text{ mA}$ | 2 | 10 | | μF | |

Refer to test circuits, $T_a = -40$ to 125 °C, $C_i = 0.1$ μ F, $C_o = 2.2$ μ F unless otherwise specified.

Table 8: LF25AB (automotive grade) electrical characteristics

| Symbol | Parameter | Test condition | Min. | Typ. | Max. | Unit |
|--------------|---------------------------|---|--------------|------|-------|---------|
| V_o | Output voltage | $I_o = 50$ mA $V_i = 4.5$ V $T_a = 25$ °C | 2.475 | 2.5 | 2.525 | V |
| | | $I_o = 50$ mA $V_i = 4.5$ V | 2.435 | | 2.565 | |
| V_i | Operating input voltage | $I_o = 500$ mA | | | 16 | V |
| I_o | Output current limit | $T_a = 25$ °C | | 1 | | A |
| ΔV_o | Line regulation | $V_i = 3.5$ to 16 V $I_o = 5$ mA | | 2 | 15 | mV |
| ΔV_o | Load regulation | $V_i = 3.8$ V $I_o = 5$ to 500 mA | | 2 | 15 | mV |
| I_d | Quiescent current | $V_i = 3.5$ to 16 V $I_o = 0$ mA | ON mode | 0.5 | 2 | mA |
| | | $V_i = 3.8$ to 16 V $I_o = 500$ mA | | | 12 | |
| | | $V_i = 6$ V | OFF mode | | 50 | 120 |
| SVR | Supply voltage rejection | $I_o = 5$ mA $V_i = 4.5 \pm 1$ V $T_a = 25$ °C | $f = 120$ Hz | 82 | | dB |
| | | | $f = 1$ kHz | 77 | | |
| | | | $f = 10$ kHz | 65 | | |
| eN | Output noise voltage | $B = 10$ Hz to 100 kHz $T_a = 25$ °C | | 50 | | μ V |
| V_d | Dropout voltage | $I_o = 200$ mA | | 0.2 | 1.3 | V |
| | | $I_o = 500$ mA | | 0.4 | 1.3 | |
| V_{IL} | Control input logic low | | | | 0.8 | V |
| V_{IH} | Control input logic high | | 2 | | | V |
| I_i | Control input current | $V_i = 6$ V $V_c = 6$ V $T_a = 25$ °C | | 10 | | μ A |
| C_o | Output bypass capacitance | ESR = 0.1 to 10 Ω $I_o = 0$ to 500 mA | 2 | 10 | | μ F |

Refer to test circuits, $T_J = 25\text{ }^\circ\text{C}$, $C_I = 0.1\text{ }\mu\text{F}$, $C_O = 2.2\text{ }\mu\text{F}$ unless otherwise specified.

Table 9: LF25C electrical characteristics

| Symbol | Parameter | Test condition | Min. | Typ. | Max. | Unit | |
|--------------|---------------------------|--|---------------------|------|------|---------------|---------------|
| V_O | Output voltage | $I_O = 50\text{ mA}$ $V_I = 4.5\text{ V}$ | 2.45 | 2.5 | 2.55 | V | |
| | | $I_O = 50\text{ mA}$ $V_I = 4.5\text{ V}$ $T_a = -25\text{ to }85\text{ }^\circ\text{C}$ | 2.4 | | 2.6 | | |
| V_I | Operating input voltage | $I_O = 500\text{ mA}$ | | | 16 | V | |
| I_O | Output current limit | | | 1 | | A | |
| ΔV_O | Line regulation | $V_I = 3.5\text{ to }16\text{ V}$ $I_O = 5\text{ mA}$ | | 2 | 12 | mV | |
| ΔV_O | Load regulation | $V_I = 3.8\text{ V}$ $I_O = 5\text{ to }500\text{ mA}$ | | 2 | 12 | mV | |
| I_d | Quiescent current | $V_I = 3.5\text{ to }16\text{ V}$ $I_O = 0\text{ mA}$ | ON mode | | 0.5 | 1 | mA |
| | | $V_I = 3.8\text{ to }16\text{ V}$ $I_O = 500\text{ mA}$ | | | 12 | | |
| | | $V_I = 6\text{ V}$ | OFF mode | | 50 | 100 | μA |
| SVR | Supply voltage rejection | $I_O = 5\text{ mA}$ $V_I = 4.5 \pm 1\text{ V}$ | $f = 120\text{ Hz}$ | | 82 | dB | |
| | | | $f = 1\text{ kHz}$ | | 77 | | |
| | | | $f = 10\text{ kHz}$ | | 65 | | |
| eN | Output noise voltage | $B = 10\text{ Hz to }100\text{ kHz}$ | | 50 | | μV | |
| V_d | Dropout voltage | $I_O = 200\text{ mA}$ | | 0.2 | 0.35 | V | |
| | | $I_O = 500\text{ mA}$ | | 0.4 | 0.7 | | |
| V_{IL} | Control input logic low | $T_a = -40\text{ to }125\text{ }^\circ\text{C}$ | | | 0.8 | V | |
| V_{IH} | Control input logic high | $T_a = -40\text{ to }125\text{ }^\circ\text{C}$ | 2 | | | V | |
| I_I | Control input current | $V_I = 6\text{ V}$ $V_C = 6\text{ V}$ | | 10 | | μA | |
| C_O | Output bypass capacitance | ESR = 0.1 to 10 Ω $I_O = 0\text{ to }500\text{ mA}$ | 2 | 10 | | μF | |

Refer to test circuits, $T_a = -40$ to 125 °C, $C_i = 0.1$ μ F, $C_o = 2.2$ μ F unless otherwise specified.

Table 10: LF25C (automotive grade) electrical characteristics

| Symbol | Parameter | Test condition | Min. | Typ. | Max. | Unit |
|--------------|---------------------------|---|--------------|------|-------|---------|
| V_o | Output voltage | $I_o = 50$ mA $V_i = 4.5$ V $T_a = 25$ °C | 2.45 | 2.5 | 2.55 | V |
| | | $I_o = 50$ mA $V_i = 4.5$ V | 2.385 | | 2.615 | |
| V_i | Operating input voltage | $I_o = 500$ mA | | | 16 | V |
| I_o | Output current limit | $T_a = 25$ °C | | 1 | | A |
| ΔV_o | Line regulation | $V_i = 3.5$ to 16 V $I_o = 5$ mA | | 2 | 15 | mV |
| ΔV_o | Load regulation | $V_i = 3.8$ V $I_o = 5$ to 500 mA | | 2 | 15 | mV |
| I_d | Quiescent current | $V_i = 3.5$ to 16 V $I_o = 0$ mA | | 0.5 | 2 | mA |
| | | $V_i = 3.8$ to 16 V $I_o = 500$ mA | | | | |
| | | $V_i = 6$ V | OFF mode | 50 | 120 | |
| SVR | Supply voltage rejection | $I_o = 5$ mA $V_i = 4.5 \pm 1$ V $T_a = 25$ °C | $f = 120$ Hz | 82 | | dB |
| | | | $f = 1$ kHz | 77 | | |
| | | | $f = 10$ kHz | 65 | | |
| eN | Output noise voltage | $B = 10$ Hz to 100 kHz $T_a = 25$ °C | | 50 | | μ V |
| V_d | Dropout voltage | $I_o = 200$ mA | | 0.2 | 1.3 | V |
| | | $I_o = 500$ mA | | 0.4 | 1.3 | |
| V_{IL} | Control input logic low | | | | 0.8 | V |
| V_{IH} | Control input logic high | | 2 | | | V |
| I_i | Control input current | $V_i = 6$ V $V_c = 6$ V $T_a = 25$ °C | | 10 | | μ A |
| C_o | Output bypass capacitance | ESR = 0.1 to 10 Ω $I_o = 0$ to 500 mA | 2 | 10 | | μ F |

Refer to test circuits, $T_J = 25\text{ }^\circ\text{C}$, $C_I = 0.1\text{ }\mu\text{F}$, $C_O = 2.2\text{ }\mu\text{F}$ unless otherwise specified.

Table 11: LF33AB electrical characteristics

| Symbol | Parameter | Test condition | Min. | Typ. | Max. | Unit | |
|--------------|---------------------------|--|---------------------|------|-------|---------------|---------------|
| V_O | Output voltage | $I_O = 50\text{ mA}$ $V_I = 5.3\text{ V}$ | 3.267 | 3.3 | 3.333 | V | |
| | | $I_O = 50\text{ mA}$ $V_I = 5.3\text{ V}$ $T_a = -25\text{ to }85\text{ }^\circ\text{C}$ | 3.234 | | 3.366 | | |
| V_I | Operating input voltage | $I_O = 500\text{ mA}$ | | | 16 | V | |
| I_O | Output current limit | | | 1 | | A | |
| ΔV_O | Line regulation | $V_I = 4.3\text{ to }16\text{ V}$ $I_O = 5\text{ mA}$ | | 3 | 16 | mV | |
| ΔV_O | Load regulation | $V_I = 4.6\text{ V}$ $I_O = 5\text{ to }500\text{ mA}$ | | 3 | 16 | mV | |
| I_d | Quiescent current | $V_I = 4.3\text{ to }16\text{ V}$ $I_O = 0\text{ mA}$ | ON mode | | 0.5 | 1 | mA |
| | | $V_I = 4.6\text{ to }16\text{ V}$ $I_O = 500\text{ mA}$ | | | | 12 | |
| | | $V_I = 6\text{ V}$ | OFF mode | | 50 | 100 | μA |
| SVR | Supply voltage rejection | $I_O = 5\text{ mA}$ $V_I = 5.3 \pm 1\text{ V}$ | $f = 120\text{ Hz}$ | | 80 | dB | |
| | | | $f = 1\text{ kHz}$ | | 75 | | |
| | | | $f = 10\text{ kHz}$ | | 65 | | |
| eN | Output noise voltage | $B = 10\text{ Hz to }100\text{ kHz}$ | | 50 | | μV | |
| V_d | Dropout voltage | $I_O = 200\text{ mA}$ | | 0.2 | 0.35 | V | |
| | | $I_O = 500\text{ mA}$ | | 0.4 | 0.7 | | |
| V_{IL} | Control input logic low | $T_a = -40\text{ to }125\text{ }^\circ\text{C}$ | | | 0.8 | V | |
| V_{IH} | Control input logic high | $T_a = -40\text{ to }125\text{ }^\circ\text{C}$ | 2 | | | V | |
| I_i | Control input current | $V_I = 6\text{ V}$ $V_C = 6\text{ V}$ | | 10 | | μA | |
| C_O | Output bypass capacitance | ESR = 0.1 to 10 Ω $I_O = 0\text{ to }500\text{ mA}$ | 2 | 10 | | μF | |

Refer to test circuits, $T_J = 25\text{ }^\circ\text{C}$, $C_I = 0.1\text{ }\mu\text{F}$, $C_O = 2.2\text{ }\mu\text{F}$ unless otherwise specified.

Table 12: LF33C electrical characteristics

| Symbol | Parameter | Test condition | Min. | Typ. | Max. | Unit | |
|--------------|---------------------------|--|---------------------|------|-------|---------------|---------------|
| V_O | Output voltage | $I_O = 50\text{ mA}$ $V_I = 5.3\text{ V}$ | 3.234 | 3.3 | 3.366 | V | |
| | | $I_O = 50\text{ mA}$ $V_I = 5.3\text{ V}$ $T_a = -25\text{ to }85\text{ }^\circ\text{C}$ | 3.168 | | 3.432 | | |
| V_I | Operating input voltage | $I_O = 500\text{ mA}$ | | | 16 | V | |
| I_O | Output current limit | | | 1 | | A | |
| ΔV_O | Line regulation | $V_I = 4.3\text{ to }16\text{ V}$ $I_O = 5\text{ mA}$ | | 3 | 16 | mV | |
| ΔV_O | Load regulation | $V_I = 4.6\text{ V}$ $I_O = 5\text{ to }500\text{ mA}$ | | 3 | 16 | mV | |
| I_d | Quiescent current | $V_I = 4.3\text{ to }16\text{ V}$ $I_O = 0\text{ mA}$ | ON mode | | 0.5 | 1 | mA |
| | | $V_I = 4.6\text{ to }16\text{ V}$ $I_O = 500\text{ mA}$ | | | | 12 | |
| | | $V_I = 6\text{ V}$ | OFF mode | | 50 | 100 | μA |
| SVR | Supply voltage rejection | $I_O = 5\text{ mA}$ $V_I = 5.3 \pm 1\text{ V}$ | $f = 120\text{ Hz}$ | | 80 | dB | |
| | | | $f = 1\text{ kHz}$ | | 75 | | |
| | | | $f = 10\text{ kHz}$ | | 65 | | |
| eN | Output noise voltage | $B = 10\text{ Hz to }100\text{ kHz}$ | | 50 | | μV | |
| V_d | Dropout voltage | $I_O = 200\text{ mA}$ | | 0.2 | 0.35 | V | |
| | | $I_O = 500\text{ mA}$ | | 0.4 | 0.7 | | |
| V_{IL} | Control input logic low | $T_a = -40\text{ to }125\text{ }^\circ\text{C}$ | | | 0.8 | V | |
| V_{IH} | Control input logic high | $T_a = -40\text{ to }125\text{ }^\circ\text{C}$ | 2 | | | V | |
| I_i | Control input current | $V_I = 6\text{ V}$ $V_C = 6\text{ V}$ | | 10 | | μA | |
| C_O | Output bypass capacitance | ESR = 0.1 to 10 Ω $I_O = 0\text{ to }500\text{ mA}$ | 2 | 10 | | μF | |

Refer to test circuits, $T_a = -40$ to 125 °C, $C_i = 0.1$ μ F, $C_o = 2.2$ μ F unless otherwise specified.

Table 13: LF33C (automotive grade) electrical characteristics

| Symbol | Parameter | Test condition | Min. | Typ. | Max. | Unit |
|--------------|---------------------------|---|--------------|------|-------|---------|
| V_o | Output voltage | $I_o = 50$ mA $V_i = 5.3$ V $T_a = 25$ °C | 3.234 | 3.3 | 3.366 | V |
| | | $I_o = 50$ mA $V_i = 5.3$ V, | 3.153 | | 3.447 | |
| V_i | Operating input voltage | $I_o = 500$ mA | | | 16 | V |
| I_o | Output current limit | $T_a = 25$ °C | | 1 | | A |
| ΔV_o | Line regulation | $V_i = 4.3$ to 16 V $I_o = 5$ mA | | 3 | 19 | mV |
| ΔV_o | Load regulation | $V_i = 4.6$ V $I_o = 5$ to 500 mA | | 3 | 19 | mV |
| I_d | Quiescent current | $V_i = 4.3$ to 16 V $I_o = 0$ mA | ON mode | 0.5 | 2 | mA |
| | | $V_i = 4.6$ to 16 V $I_o = 500$ mA | | | | |
| | | $V_i = 6$ V | OFF mode | 50 | 120 | |
| SVR | Supply voltage rejection | $I_o = 5$ mA $V_i = 5.3 \pm 1$ V $T_a = 25$ °C | $f = 120$ Hz | 80 | | dB |
| | | | $f = 1$ kHz | 75 | | |
| | | | $f = 10$ kHz | 65 | | |
| eN | Output noise voltage | $B = 10$ Hz to 100 kHz $T_a = 25$ °C | | 50 | | μ V |
| V_d | Dropout voltage | $I_o = 200$ mA | | 0.2 | 1.3 | V |
| | | $I_o = 500$ mA | | 0.4 | 1.3 | |
| V_{IL} | Control input logic low | | | | 0.8 | V |
| V_{IH} | Control input logic high | | 2 | | | V |
| I_i | Control input current | $V_i = 6$ V $V_c = 6$ V $T_a = 25$ °C | | 10 | | μ A |
| C_o | Output bypass capacitance | ESR = 0.1 to 10 Ω $I_o = 0$ to 500 mA | 2 | 10 | | μ F |

Refer to test circuits, $T_a = -40$ to 125 °C, $C_i = 0.1$ μ F, $C_o = 2.2$ μ F unless otherwise specified.

Table 14: LF50AB electrical characteristics

| Symbol | Parameter | Test condition | Min. | Typ. | Max. | Unit | |
|--------------|---------------------------|--|--------------|------|------|---------|---------|
| V_o | Output voltage | $I_o = 50$ mA $V_i = 7$ V | 4.95 | 5 | 5.05 | V | |
| | | $I_o = 50$ mA $V_i = 7$ V $T_a = -25$ to 85 °C | 4.9 | | 5.1 | | |
| V_i | Operating input voltage | $I_o = 500$ mA | | | 16 | V | |
| I_o | Output current limit | | | 1 | | A | |
| ΔV_o | Line regulation | $V_i = 6$ to 16 V $I_o = 5$ mA | | 5 | 25 | mV | |
| ΔV_o | Load regulation | $V_i = 6.3$ V $I_o = 5$ to 500 mA | | 5 | 25 | mV | |
| I_d | Quiescent current | $V_i = 6$ to 16 V $I_o = 0$ mA | ON mode | | 0.5 | 1 | mA |
| | | $V_i = 6.3$ to 16 V $I_o = 500$ mA | | | 12 | | |
| | | $V_i = 6$ V | OFF mode | | 50 | 100 | μ A |
| SVR | Supply voltage rejection | $I_o = 5$ mA $V_i = 7 \pm 1$ V | $f = 120$ Hz | | 76 | dB | |
| | | | $f = 1$ kHz | | 71 | | |
| | | | $f = 10$ kHz | | 60 | | |
| eN | Output noise voltage | $B = 10$ Hz to 100 kHz | | 50 | | μ V | |
| V_d | Dropout voltage | $I_o = 200$ mA | | 0.2 | 0.35 | V | |
| | | $I_o = 500$ mA | | 0.4 | 0.7 | | |
| V_{iL} | Control input logic low | $T_a = -40$ to 125 °C | | | 0.8 | V | |
| V_{iH} | Control input logic high | $T_a = -40$ to 125 °C | 2 | | | V | |
| I_i | Control input current | $V_i = 6$ V $V_c = 6$ V | | 10 | | μ A | |
| C_o | Output bypass capacitance | ESR = 0.1 to 10 Ω $I_o = 0$ to 500 mA | 2 | 10 | | μ F | |

Refer to test circuits, $T_a = -40$ to 125 °C, $C_i = 0.1$ μ F, $C_o = 2.2$ μ F unless otherwise specified.

Table 15: LF50AB (automotive grade) electrical characteristics

| Symbol | Parameter | Test condition | Min. | Typ. | Max. | Unit | |
|--------------|---------------------------|---|--------------|------|-------|---------|---------|
| V_o | Output voltage | $I_o = 50$ mA $V_i = 7$ V $T_a = 25$ °C | 4.95 | 5 | 5.05 | V | |
| | | $I_o = 50$ mA $V_i = 7$ V | 4.885 | | 5.115 | | |
| V_i | Operating input voltage | $I_o = 500$ mA | | | 16 | V | |
| I_o | Output current limit | $T_a = 25$ °C | | 1 | | A | |
| ΔV_o | Line regulation | $V_i = 6$ to 16 V $I_o = 5$ mA | | 5 | 28 | mV | |
| ΔV_o | Load regulation | $V_i = 6.3$ V $I_o = 5$ to 500 mA | | 5 | 28 | mV | |
| I_d | Quiescent current | $V_i = 6$ to 16 V $I_o = 0$ mA | ON mode | | 0.5 | 2 | mA |
| | | $V_i = 6.3$ to 16 V $I_o = 500$ mA | | | | 12 | |
| | | $V_i = 6$ V | OFF mode | | 50 | 120 | μ A |
| SVR | Supply voltage rejection | $I_o = 5$ mA $V_i = 7 \pm 1$ V $T_a = 25$ °C | $f = 120$ Hz | | 76 | dB | |
| | | | $f = 1$ kHz | | 71 | | |
| | | | $f = 10$ kHz | | 60 | | |
| eN | Output noise voltage | $B = 10$ Hz to 100 kHz $T_a = 25$ °C | | 50 | | μ V | |
| V_d | Dropout voltage | $I_o = 200$ mA | | 0.2 | 1.3 | V | |
| | | $I_o = 500$ mA | | 0.4 | 1.3 | | |
| V_{IL} | Control input logic low | | | | 0.8 | V | |
| V_{IH} | Control input logic high | | 2 | | | V | |
| I_i | Control input current | $V_i = 6$ V $V_c = 6$ V $T_a = 25$ °C | | 10 | | μ A | |
| C_o | Output bypass capacitance | ESR = 0.1 to 10 Ω $I_o = 0$ to 500 mA | 2 | 10 | | μ F | |

Refer to test circuits, $T_J = 25\text{ }^\circ\text{C}$, $C_I = 0.1\text{ }\mu\text{F}$, $C_O = 2.2\text{ }\mu\text{F}$ unless otherwise specified.

Table 16: LF50AC electrical characteristics

| Symbol | Parameter | Test condition | Min. | Typ. | Max. | Unit | |
|--------------|---------------------------|--|---------------------|------|-------|---------------|---------------|
| V_O | Output voltage | $I_O = 50\text{ mA}$ $V_I = 7\text{ V}$ | 4.925 | 5 | 5.075 | V | |
| | | $I_O = 50\text{ mA}$ $V_I = 7\text{ V}$ $T_a = -25\text{ to }85\text{ }^\circ\text{C}$ | 4.875 | | 5.125 | | |
| V_I | Operating input voltage | $I_O = 500\text{ mA}$ | | | 16 | V | |
| I_O | Output current limit | | | 1 | | A | |
| ΔV_O | Line regulation | $V_I = 6\text{ to }16\text{ V}$ $I_O = 5\text{ mA}$ | | 5 | 25 | mV | |
| ΔV_O | Load regulation | $V_I = 6.3\text{ V}$ $I_O = 5\text{ to }500\text{ mA}$ | | 5 | 25 | mV | |
| I_d | Quiescent current | $V_I = 6\text{ to }16\text{ V}$ $I_O = 0\text{ mA}$ | ON mode | | 0.5 | 1 | mA |
| | | $V_I = 6.3\text{ to }16\text{ V}$ $I_O = 500\text{ mA}$ | | | | 12 | |
| | | $V_I = 6\text{ V}$ | OFF mode | | 50 | 100 | μA |
| SVR | Supply voltage rejection | $I_O = 5\text{ mA}$ $V_I = 7 \pm 1\text{ V}$ | $f = 120\text{ Hz}$ | | 76 | dB | |
| | | | $f = 1\text{ kHz}$ | | 71 | | |
| | | | $f = 10\text{ kHz}$ | | 60 | | |
| eN | Output noise voltage | $B = 10\text{ Hz to }100\text{ kHz}$ | | 50 | | μV | |
| V_d | Dropout voltage | $I_O = 200\text{ mA}$ | | 0.2 | 0.35 | V | |
| | | $I_O = 500\text{ mA}$ | | 0.4 | 0.7 | | |
| V_{IL} | Control input logic low | $T_a = -40\text{ to }125\text{ }^\circ\text{C}$ | | | 0.8 | V | |
| V_{IH} | Control input logic high | $T_a = -40\text{ to }125\text{ }^\circ\text{C}$ | 2 | | | V | |
| I_i | Control input current | $V_I = 6\text{ V}$ $V_C = 6\text{ V}$ | | 10 | | μA | |
| C_O | Output bypass capacitance | ESR = 0.1 to 10 Ω $I_O = 0\text{ to }500\text{ mA}$ | 2 | 10 | | μF | |

Refer to test circuits, $T_J = 25\text{ °C}$, $C_I = 0.1\text{ }\mu\text{F}$, $C_O = 2.2\text{ }\mu\text{F}$ unless otherwise specified.

Table 17: LF50C electrical characteristics

| Symbol | Parameter | Test condition | Min. | Typ. | Max. | Unit | |
|--------------|---------------------------|--|---------------------|------|------|---------------|---------------|
| V_O | Output voltage | $I_O = 50\text{ mA}$ $V_I = 7\text{ V}$ | 4.9 | 5 | 5.1 | V | |
| | | $I_O = 50\text{ mA}$ $V_I = 7\text{ V}$ $T_a = -25\text{ to }85\text{ °C}$ | 4.8 | | 5.2 | | |
| V_I | Operating input voltage | $I_O = 500\text{ mA}$ | | | 16 | V | |
| I_O | Output current limit | | | 1 | | A | |
| ΔV_O | Line regulation | $V_I = 6\text{ to }16\text{ V}$ $I_O = 5\text{ mA}$ | | 5 | 25 | mV | |
| ΔV_O | Load regulation | $V_I = 6.3\text{ V}$ $I_O = 5\text{ to }500\text{ mA}$ | | 5 | 25 | mV | |
| I_d | Quiescent current | $V_I = 6\text{ to }16\text{ V}$ $I_O = 0\text{ mA}$ | ON mode | | 0.5 | 1 | mA |
| | | $V_I = 6.3\text{ to }16\text{ V}$ $I_O = 500\text{ mA}$ | | | | 12 | |
| | | $V_I = 6\text{ V}$ | OFF mode | | 50 | 100 | μA |
| SVR | Supply voltage rejection | $I_O = 5\text{ mA}$ $V_I = 7 \pm 1\text{ V}$ | $f = 120\text{ Hz}$ | | 76 | dB | |
| | | | $f = 1\text{ kHz}$ | | 71 | | |
| | | | $f = 10\text{ kHz}$ | | 60 | | |
| eN | Output noise voltage | $B = 10\text{ Hz to }100\text{ kHz}$ | | 50 | | μV | |
| V_d | Dropout voltage | $I_O = 200\text{ mA}$ | | 0.2 | 0.35 | V | |
| | | $I_O = 500\text{ mA}$ | | 0.4 | 0.7 | | |
| V_{IL} | Control input logic low | $T_a = -40\text{ to }125\text{ °C}$ | | | 0.8 | V | |
| V_{IH} | Control input logic high | $T_a = -40\text{ to }125\text{ °C}$ | 2 | | | V | |
| I_i | Control input current | $V_I = 6\text{ V}$ $V_C = 6\text{ V}$ | | 10 | | μA | |
| C_O | Output bypass capacitance | ESR = 0.1 to 10 Ω $I_O = 0\text{ to }500\text{ mA}$ | 2 | 10 | | μF | |

Refer to test circuits, $T_a = -40$ to 125 °C, $C_i = 0.1$ μ F, $C_o = 2.2$ μ F unless otherwise specified.

Table 18: LF50C (automotive grade) electrical characteristics

| Symbol | Parameter | Test condition | Min. | Typ. | Max. | Unit | |
|--------------|---------------------------|---|--------------|------|-------|---------|---------|
| V_o | Output voltage | $I_o = 50$ mA $V_i = 7$ V $T_a = 25$ °C | 4.9 | 5 | 5.1 | V | |
| | | $I_o = 50$ mA $V_i = 7$ V | 4.785 | | 5.215 | | |
| V_i | Operating input voltage | $I_o = 500$ mA | | | 16 | V | |
| I_o | Output current limit | $T_a = 25$ °C | | 1 | | A | |
| ΔV_o | Line regulation | $V_i = 6$ to 16 V $I_o = 5$ mA | | 5 | 28 | mV | |
| ΔV_o | Load regulation | $V_i = 6.3$ V $I_o = 5$ to 500 mA | | 5 | 28 | mV | |
| I_d | Quiescent current | $V_i = 6$ to 16 V $I_o = 0$ mA | ON mode | | 0.5 | 2 | mA |
| | | $V_i = 6.3$ to 16 V $I_o = 500$ mA | | | | 12 | |
| | | $V_i = 6$ V | OFF mode | | 50 | 120 | μ A |
| SVR | Supply voltage rejection | $I_o = 5$ mA $V_i = 7 \pm 1$ V $T_a = 25$ °C | $f = 120$ Hz | | 76 | | dB |
| | | | $f = 1$ kHz | | 71 | | |
| | | | $f = 10$ kHz | | 60 | | |
| eN | Output noise voltage | $B = 10$ Hz to 100 kHz $T_a = 25$ °C | | 50 | | μ V | |
| V_d | Dropout voltage | $I_o = 200$ mA | | 0.2 | 1.3 | V | |
| | | $I_o = 500$ mA | | 0.4 | 1.3 | | |
| V_{IL} | Control input logic low | | | | 0.8 | V | |
| V_{IH} | Control input logic high | | 2 | | | V | |
| I_i | Control input current | $V_i = 6$ V $V_C = 6$ V $T_a = 25$ °C | | 10 | | μ A | |
| C_o | Output bypass capacitance | ESR = 0.1 to 10 Ω $I_o = 0$ to 500 mA | 2 | 10 | | μ F | |

Refer to test circuits, $T_J = 25\text{ }^\circ\text{C}$, $C_I = 0.1\text{ }\mu\text{F}$, $C_O = 2.2\text{ }\mu\text{F}$ unless otherwise specified.

Table 19: LF60AB electrical characteristics

| Symbol | Parameter | Test condition | Min. | Typ. | Max. | Unit | |
|--------------|---------------------------|--|---------------------|------|------|---------------|---------------|
| V_O | Output voltage | $I_O = 50\text{ mA}$ $V_I = 8\text{ V}$ | 5.94 | 6 | 6.06 | V | |
| | | $I_O = 50\text{ mA}$ $V_I = 8\text{ V}$ $T_a = -25\text{ to }85\text{ }^\circ\text{C}$ | 5.88 | | 6.12 | | |
| V_I | Operating input voltage | $I_O = 500\text{ mA}$ | | | 16 | V | |
| I_O | Output current limit | | | 1 | | A | |
| ΔV_O | Line regulation | $V_I = 7\text{ to }16\text{ V}$ $I_O = 5\text{ mA}$ | | 6 | 30 | mV | |
| ΔV_O | Load regulation | $V_I = 7.3\text{ V}$ $I_O = 5\text{ to }500\text{ mA}$ | | 6 | 30 | mV | |
| I_d | Quiescent current | $V_I = 7\text{ to }16\text{ V}$ $I_O = 0\text{ mA}$ | ON mode | | 0.7 | 1.5 | mA |
| | | $V_I = 7.3\text{ to }16\text{ V}$ $I_O = 500\text{ mA}$ | | | | 12 | |
| | | $V_I = 9\text{ V}$ | OFF mode | | 70 | 140 | μA |
| SVR | Supply voltage rejection | $I_O = 5\text{ mA}$ $V_I = 8 \pm 1\text{ V}$ | $f = 120\text{ Hz}$ | | 75 | | dB |
| | | | $f = 1\text{ kHz}$ | | 70 | | |
| | | | $f = 10\text{ kHz}$ | | 60 | | |
| eN | Output noise voltage | $B = 10\text{ Hz to }100\text{ kHz}$ | | 50 | | μV | |
| V_d | Dropout voltage | $I_O = 200\text{ mA}$ | | 0.2 | 0.35 | V | |
| | | $I_O = 500\text{ mA}$ | | 0.4 | 0.7 | | |
| V_{IL} | Control input logic low | $T_a = -40\text{ to }125\text{ }^\circ\text{C}$ | | | 0.8 | V | |
| V_{IH} | Control input logic high | $T_a = -40\text{ to }125\text{ }^\circ\text{C}$ | 2 | | | V | |
| I_i | Control input current | $V_I = 9\text{ V}$ $V_C = 6\text{ V}$ | | 10 | | μA | |
| C_O | Output bypass capacitance | ESR = 0.1 to 10 Ω $I_O = 0\text{ to }500\text{ mA}$ | 2 | 10 | | μF | |

Refer to test circuits, $T_J = 25\text{ }^\circ\text{C}$, $C_I = 0.1\text{ }\mu\text{F}$, $C_O = 2.2\text{ }\mu\text{F}$ unless otherwise specified.

Table 20: LF60C electrical characteristics

| Symbol | Parameter | Test condition | Min. | Typ. | Max. | Unit | |
|--------------|---------------------------|--|---------------------|---------|------|---------------|----|
| V_O | Output voltage | $I_O = 50\text{ mA}$ $V_I = 8\text{ V}$ | 5.88 | 6 | 6.12 | V | |
| | | $I_O = 50\text{ mA}$ $V_I = 8\text{ V}$ $T_a = -25\text{ to }85\text{ }^\circ\text{C}$ | 5.76 | | 6.24 | | |
| V_I | Operating input voltage | $I_O = 500\text{ mA}$ | | | 16 | V | |
| I_O | Output current limit | | | 1 | | A | |
| ΔV_O | Line regulation | $V_I = 7\text{ to }16\text{ V}$ $I_O = 5\text{ mA}$ | | 6 | 30 | mV | |
| ΔV_O | Load regulation | $V_I = 7.3\text{ V}$ $I_O = 5\text{ to }500\text{ mA}$ | | 6 | 30 | mV | |
| I_d | Quiescent current | $V_I = 7\text{ to }16\text{ V}$ $I_O = 0\text{ mA}$ | | ON mode | 0.7 | 1.5 | mA |
| | | $V_I = 7.3\text{ to }16\text{ V}$ $I_O = 500\text{ mA}$ | | | | 12 | |
| | | $V_I = 9\text{ V}$ | OFF mode | 70 | 140 | μA | |
| SVR | Supply voltage rejection | $I_O = 5\text{ mA}$ $V_I = 8 \pm 1\text{ V}$ | $f = 120\text{ Hz}$ | | 75 | dB | |
| | | | $f = 1\text{ kHz}$ | | 70 | | |
| | | | $f = 10\text{ kHz}$ | | 60 | | |
| eN | Output noise voltage | $B = 10\text{ Hz to }100\text{ kHz}$ | | 50 | | μV | |
| V_d | Dropout voltage | $I_O = 200\text{ mA}$ | | 0.2 | 0.35 | V | |
| | | $I_O = 500\text{ mA}$ | | 0.4 | 0.7 | | |
| V_{IL} | Control input logic low | $T_a = -40\text{ to }125\text{ }^\circ\text{C}$ | | | 0.8 | V | |
| V_{IH} | Control input logic high | $T_a = -40\text{ to }125\text{ }^\circ\text{C}$ | 2 | | | V | |
| I_i | Control input current | $V_I = 9\text{ V}$ $V_C = 6\text{ V}$ | | 10 | | μA | |
| C_O | Output bypass capacitance | ESR = 0.1 to 10 Ω $I_O = 0\text{ to }500\text{ mA}$ | 2 | 10 | | μF | |

Refer to test circuits, $T_J = 25\text{ °C}$, $C_I = 0.1\text{ }\mu\text{F}$, $C_O = 2.2\text{ }\mu\text{F}$ unless otherwise specified.

Table 21: LF80AB electrical characteristics

| Symbol | Parameter | Test condition | Min. | Typ. | Max. | Unit | |
|--------------|---------------------------|---|---------------------|---------|------|---------------|---------------|
| V_O | Output voltage | $I_O = 50\text{ mA}$ $V_I = 10\text{ V}$ | 7.92 | 8 | 8.08 | V | |
| | | $I_O = 50\text{ mA}$ $V_I = 10\text{ V}$ $T_a = -25\text{ to }85\text{ °C}$ | 7.84 | | 8.16 | | |
| V_I | Operating input voltage | $I_O = 500\text{ mA}$ | | | 16 | V | |
| I_O | Output current limit | | | 1 | | A | |
| ΔV_O | Line regulation | $V_I = 9\text{ to }16\text{ V}$ $I_O = 5\text{ mA}$ | | 8 | 40 | mV | |
| ΔV_O | Load regulation | $V_I = 9.3\text{ V}$ $I_O = 5\text{ to }500\text{ mA}$ | | 8 | 40 | mV | |
| I_d | Quiescent current | $V_I = 9\text{ to }16\text{ V}$ $I_O = 0\text{ mA}$ | | ON mode | 0.7 | 1.5 | mA |
| | | $V_I = 9.3\text{ to }16\text{ V}$ $I_O = 500\text{ mA}$ | | | | 12 | |
| | | $V_I = 9\text{ V}$ | OFF mode | | 70 | 140 | μA |
| SVR | Supply voltage rejection | $I_O = 5\text{ mA}$ $V_I = 10 \pm 1\text{ V}$ | $f = 120\text{ Hz}$ | | 72 | dB | |
| | | | $f = 1\text{ kHz}$ | | 67 | | |
| | | | $f = 10\text{ kHz}$ | | 57 | | |
| eN | Output noise voltage | $B = 10\text{ Hz to }100\text{ kHz}$ | | 50 | | μV | |
| V_d | Dropout voltage | $I_O = 200\text{ mA}$ | | 0.2 | 0.35 | V | |
| | | $I_O = 500\text{ mA}$ | | 0.4 | 0.7 | | |
| V_{IL} | Control input logic low | $T_a = -40\text{ to }125\text{ °C}$ | | | 0.8 | V | |
| V_{IH} | Control input logic high | $T_a = -40\text{ to }125\text{ °C}$ | 2 | | | V | |
| I_i | Control input current | $V_I = 9\text{ V}$ $V_C = 6\text{ V}$ | | 10 | | μA | |
| C_O | Output bypass capacitance | ESR = 0.1 to 10 Ω $I_O = 0\text{ to }500\text{ mA}$ | 2 | 10 | | μF | |

Refer to test circuits, $T_J = 25\text{ }^\circ\text{C}$, $C_I = 0.1\text{ }\mu\text{F}$, $C_O = 2.2\text{ }\mu\text{F}$ unless otherwise specified.

Table 22: LF80C electrical characteristics

| Symbol | Parameter | Test condition | Min. | Typ. | Max. | Unit |
|--------------|---------------------------|---|---------------------|------|------|---------------|
| V_O | Output voltage | $I_O = 50\text{ mA}$ $V_I = 10\text{ V}$ | 7.84 | 8 | 8.16 | V |
| | | $I_O = 50\text{ mA}$ $V_I = 10\text{ V}$ $T_a = -25\text{ to }85\text{ }^\circ\text{C}$ | 7.68 | | 8.32 | |
| V_I | Operating input voltage | $I_O = 500\text{ mA}$ | | | 16 | V |
| I_O | Output current limit | | | 1 | | A |
| ΔV_O | Line regulation | $V_I = 9\text{ to }16\text{ V}$ $I_O = 5\text{ mA}$ | | 8 | 40 | mV |
| ΔV_O | Load regulation | $V_I = 9.3\text{ V}$ $I_O = 5\text{ to }500\text{ mA}$ | | 8 | 40 | mV |
| I_d | Quiescent current | $V_I = 9\text{ to }16\text{ V}$ $I_O = 0\text{ mA}$ | | 0.7 | 1.5 | mA |
| | | $V_I = 9.3\text{ to }16\text{ V}$ $I_O = 500\text{ mA}$ | | | | |
| | | $V_I = 9\text{ V}$ | OFF mode | 70 | 140 | |
| SVR | Supply voltage rejection | $I_O = 5\text{ mA}$ $V_I = 10 \pm 1\text{ V}$ | $f = 120\text{ Hz}$ | | 72 | dB |
| | | | $f = 1\text{ kHz}$ | | 67 | |
| | | | $f = 10\text{ kHz}$ | | 57 | |
| eN | Output noise voltage | $B = 10\text{ Hz to }100\text{ kHz}$ | | 50 | | μV |
| V_d | Dropout voltage | $I_O = 200\text{ mA}$ | | 0.2 | 0.35 | V |
| | | $I_O = 500\text{ mA}$ | | 0.4 | 0.7 | |
| V_{IL} | Control input logic low | $T_a = -40\text{ to }125\text{ }^\circ\text{C}$ | | | 0.8 | V |
| V_{IH} | Control input logic high | $T_a = -40\text{ to }125\text{ }^\circ\text{C}$ | 2 | | | V |
| I_i | Control input current | $V_I = 9\text{ V}$ $V_C = 6\text{ V}$ | | 10 | | μA |
| C_O | Output bypass capacitance | ESR = 0.1 to 10 Ω $I_O = 0\text{ to }500\text{ mA}$ | 2 | 10 | | μF |

Refer to test circuits, $T_a = -40$ to 125 °C, $C_i = 0.1$ μ F, $C_o = 2.2$ μ F unless otherwise specified.

Table 23: LF80C (automotive grade) electrical characteristics

| Symbol | Parameter | Test condition | Min. | Typ. | Max. | Unit | |
|--------------|---------------------------|---|--------------|------|-------|---------|---------|
| V_o | Output voltage | $I_o = 50$ mA $V_i = 10$ V $T_a = 25$ °C | 7.84 | 8 | 8.16 | V | |
| | | $I_o = 50$ mA $V_i = 10$ V | 7.665 | | 8.335 | | |
| V_i | Operating input voltage | $I_o = 500$ mA | | | 16 | V | |
| I_o | Output current limit | $T_a = 25$ °C | | 1 | | A | |
| ΔV_o | Line regulation | $V_i = 9$ to 16 V $I_o = 5$ mA | | 8 | 44 | mV | |
| ΔV_o | Load regulation | $V_i = 9.3$ V $I_o = 5$ to 500 mA | | 8 | 44 | mV | |
| I_d | Quiescent current | $V_i = 9$ to 16 V $I_o = 0$ mA | ON mode | | 0.7 | 2.5 | mA |
| | | $V_i = 9.3$ to 16 V $I_o = 500$ mA | | | 12 | | |
| | | $V_i = 9$ V | OFF mode | | 70 | 160 | μ A |
| SVR | Supply voltage rejection | $I_o = 5$ mA $V_i = 10 \pm 1$ V $T_a = 25$ °C | $f = 120$ Hz | | 72 | dB | |
| | | | $f = 1$ kHz | | 67 | | |
| | | | $f = 10$ kHz | | 57 | | |
| eN | Output noise voltage | $B = 10$ Hz to 100 kHz $T_a = 25$ °C | | 50 | | μ V | |
| V_d | Dropout voltage | $I_o = 200$ mA | | 0.2 | 1.3 | V | |
| | | $I_o = 500$ mA | | 0.4 | 1.3 | | |
| V_{IL} | Control input logic low | | | | 0.8 | V | |
| V_{IH} | Control input logic high | | 2 | | | V | |
| I_i | Control input current | $V_i = 9$ V $V_c = 6$ V $T_a = 25$ °C | | 10 | | μ A | |
| C_o | Output bypass capacitance | ESR = 0.1 to 10 Ω $I_o = 0$ to 500 mA | 2 | 10 | | μ F | |

Refer to test circuits, $T_J = 25\text{ }^\circ\text{C}$, $C_I = 0.1\text{ }\mu\text{F}$, $C_O = 2.2\text{ }\mu\text{F}$ unless otherwise specified.

Table 24: LF85AB electrical characteristics

| Symbol | Parameter | Test condition | Min. | Typ. | Max. | Unit | |
|--------------|---------------------------|---|---------------------|------|-------|---------------|---------------|
| V_O | Output voltage | $I_O = 50\text{ mA}$ $V_I = 10.5\text{ V}$ | 8.415 | 8.5 | 8.585 | V | |
| | | $I_O = 50\text{ mA}$ $V_I = 10.5\text{ V}$ $T_a = -25\text{ to }85\text{ }^\circ\text{C}$ | 8.33 | | 8.67 | | |
| V_I | Operating input voltage | $I_O = 500\text{ mA}$ | | | 16 | V | |
| I_O | Output current limit | | | 1 | | A | |
| ΔV_O | Line regulation | $V_I = 9.5\text{ to }16\text{ V}$ $I_O = 5\text{ mA}$ | | 8 | 42 | mV | |
| ΔV_O | Load regulation | $V_I = 9.8\text{ V}$ $I_O = 5\text{ to }500\text{ mA}$ | | 8 | 42 | mV | |
| I_d | Quiescent current | $V_I = 9.5\text{ to }16\text{ V}$ $I_O = 0\text{ mA}$ | ON mode | | 0.7 | 1.5 | mA |
| | | $V_I = 9.8\text{ to }16\text{ V}$ $I_O = 500\text{ mA}$ | | | | 12 | |
| | | $V_I = 9\text{ V}$ | OFF mode | | 70 | 140 | μA |
| SVR | Supply voltage rejection | $I_O = 5\text{ mA}$ $V_I = 10.5 \pm 1\text{ V}$ | $f = 120\text{ Hz}$ | | 72 | dB | |
| | | | $f = 1\text{ kHz}$ | | 67 | | |
| | | | $f = 10\text{ kHz}$ | | 57 | | |
| eN | Output noise voltage | $B = 10\text{ Hz to }100\text{ kHz}$ | | 50 | | μV | |
| V_d | Dropout voltage | $I_O = 200\text{ mA}$ | | 0.2 | 0.35 | V | |
| | | $I_O = 500\text{ mA}$ | | 0.4 | 0.7 | | |
| V_{IL} | Control input logic low | $T_a = -40\text{ to }125\text{ }^\circ\text{C}$ | | | 0.8 | V | |
| V_{IH} | Control input logic high | $T_a = -40\text{ to }125\text{ }^\circ\text{C}$ | 2 | | | V | |
| I_i | Control input current | $V_I = 9\text{ V}$ $V_C = 6\text{ V}$ | | 10 | | μA | |
| C_O | Output bypass capacitance | ESR = 0.1 to 10 Ω $I_O = 0\text{ to }500\text{ mA}$ | 2 | 10 | | μF | |

Refer to test circuits, $T_J = 25\text{ }^\circ\text{C}$, $C_I = 0.1\text{ }\mu\text{F}$, $C_O = 2.2\text{ }\mu\text{F}$ unless otherwise specified.

Table 25: LF85C electrical characteristics

| Symbol | Parameter | Test condition | Min. | Typ. | Max. | Unit | |
|--------------|---------------------------|---|---------------------|------|------|---------------|---------------|
| V_O | Output voltage | $I_O = 50\text{ mA}$ $V_I = 10.5\text{ V}$ | 8.33 | 8.5 | 8.67 | V | |
| | | $I_O = 50\text{ mA}$ $V_I = 10.5\text{ V}$ $T_a = -25\text{ to }85\text{ }^\circ\text{C}$ | 8.16 | | 8.84 | | |
| V_I | Operating input voltage | $I_O = 500\text{ mA}$ | | | 16 | V | |
| I_O | Output current limit | | | 1 | | A | |
| ΔV_O | Line regulation | $V_I = 9.5\text{ to }16\text{ V}$ $I_O = 5\text{ mA}$ | | 8 | 42 | mV | |
| ΔV_O | Load regulation | $V_I = 9.8\text{ V}$ $I_O = 5\text{ to }500\text{ mA}$ | | 8 | 42 | mV | |
| I_d | Quiescent current | $V_I = 9.5\text{ to }16\text{ V}$ $I_O = 0\text{ mA}$ | ON mode | | 0.7 | 1.5 | mA |
| | | $V_I = 9.8\text{ to }16\text{ V}$ $I_O = 500\text{ mA}$ | | | | 12 | |
| | | $V_I = 9\text{ V}$ | OFF mode | | 70 | 140 | μA |
| SVR | Supply voltage rejection | $I_O = 5\text{ mA}$ $V_I = 10.5 \pm 1\text{ V}$ | $f = 120\text{ Hz}$ | | 72 | | dB |
| | | | $f = 1\text{ kHz}$ | | 67 | | |
| | | | $f = 10\text{ kHz}$ | | 57 | | |
| eN | Output noise voltage | $B = 10\text{ Hz to }100\text{ kHz}$ | | 50 | | μV | |
| V_d | Dropout voltage | $I_O = 200\text{ mA}$ | | 0.2 | 0.35 | V | |
| | | $I_O = 500\text{ mA}$ | | 0.4 | 0.7 | | |
| V_{IL} | Control input logic low | $T_a = -40\text{ to }125\text{ }^\circ\text{C}$ | | | 0.8 | V | |
| V_{IH} | Control input logic high | $T_a = -40\text{ to }125\text{ }^\circ\text{C}$ | 2 | | | V | |
| I_i | Control input current | $V_I = 9\text{ V}$ $V_C = 6\text{ V}$ | | 10 | | μA | |
| C_O | Output bypass capacitance | ESR = 0.1 to 10 Ω $I_O = 0\text{ to }500\text{ mA}$ | 2 | 10 | | μF | |

Refer to test circuits, $T_a = -40$ to 125 °C, $C_i = 0.1$ μ F, $C_o = 2.2$ μ F unless otherwise specified.

Table 26: LF85C (automotive grade) electrical characteristics

| Symbol | Parameter | Test condition | Min. | Typ. | Max. | Unit |
|--------------|---------------------------|---|--------------|------|-------|---------|
| V_o | Output voltage | $I_o = 50$ mA $V_i = 10.5$ V $T_a = 25$ °C | 8.33 | 8.5 | 8.67 | V |
| | | $I_o = 50$ mA $V_i = 10.5$ V | 8.145 | | 8.855 | |
| V_i | Operating input voltage | $I_o = 500$ mA | | | 16 | V |
| I_o | Output current limit | $T_a = 25$ °C | | 1 | | A |
| ΔV_o | Line regulation | $V_i = 9.5$ to 16 V $I_o = 5$ mA | | 8 | 44 | mV |
| ΔV_o | Load regulation | $V_i = 9.8$ V $I_o = 5$ to 500 mA | | 8 | 44 | mV |
| I_d | Quiescent current | $V_i = 9.5$ to 16 V $I_o = 0$ mA | ON mode | 0.7 | 2.5 | mA |
| | | $V_i = 9.8$ to 16 V $I_o = 500$ mA | | | 12 | |
| | | $V_i = 9$ V | OFF mode | 70 | 160 | μ A |
| SVR | Supply voltage rejection | $I_o = 5$ mA $V_i = 10.5 \pm 1$ V $T_a = 25$ °C | $f = 120$ Hz | 72 | | dB |
| | | | $f = 1$ kHz | 67 | | |
| | | | $f = 10$ kHz | 57 | | |
| eN | Output noise voltage | B = 10 Hz to 100 kHz $T_a = 25$ °C | | 50 | | μ V |
| V_d | Dropout voltage | $I_o = 200$ mA | | 0.2 | 1.3 | V |
| | | $I_o = 500$ mA | | 0.4 | 1.3 | |
| V_{IL} | Control input logic low | | | | 0.8 | V |
| V_{IH} | Control input logic high | | 2 | | | V |
| I_i | Control input current | $V_i = 9$ V $V_c = 6$ V $T_a = 25$ °C | | 10 | | μ A |
| C_o | Output bypass capacitance | ESR = 0.1 to 10 Ω $I_o = 0$ to 500 mA | 2 | 10 | | μ F |

Refer to test circuits, $T_J = 25\text{ °C}$, $C_I = 0.1\text{ }\mu\text{F}$, $C_O = 2.2\text{ }\mu\text{F}$ unless otherwise specified.

Table 27: LF90C electrical characteristics

| Symbol | Parameter | Test condition | Min. | Typ. | Max. | Unit | |
|--------------|---------------------------|---|----------|---------------------|------|---------------|---------------|
| V_O | Output voltage | $I_O = 50\text{ mA}$ $V_I = 11\text{ V}$ | 8.82 | 9 | 9.18 | V | |
| | | $I_O = 50\text{ mA}$ $V_I = 11\text{ V}$ $T_a = -25\text{ to }85\text{ °C}$ | 8.64 | | 9.36 | | |
| V_I | Operating input voltage | $I_O = 500\text{ mA}$ | | | 16 | V | |
| I_O | Output current limit | | | 1 | | A | |
| ΔV_O | Line regulation | $V_I = 10\text{ to }16\text{ V}$ $I_O = 5\text{ mA}$ | | 9 | 45 | mV | |
| ΔV_O | Load regulation | $V_I = 10.3\text{ V}$ $I_O = 5\text{ to }500\text{ mA}$ | | 9 | 45 | mV | |
| I_d | Quiescent current | $V_I = 10\text{ to }16\text{ V}$ $I_O = 0\text{ mA}$ | | ON mode | 0.7 | 1.5 | mA |
| | | $V_I = 10.3\text{ to }16\text{ V}$ $I_O = 500\text{ mA}$ | | | | 12 | |
| | | $V_I = 10\text{ V}$ | OFF mode | | 70 | 140 | μA |
| SVR | Supply voltage rejection | $I_O = 5\text{ mA}$ $V_I = 11 \pm 1\text{ V}$ | | $f = 120\text{ Hz}$ | | 71 | dB |
| | | | | $f = 1\text{ kHz}$ | | 66 | |
| | | | | $f = 10\text{ kHz}$ | | 56 | |
| eN | Output noise voltage | $B = 10\text{ Hz to }100\text{ kHz}$ | | | 50 | μV | |
| V_d | Dropout voltage | $I_O = 200\text{ mA}$ | | | 0.2 | 0.35 | V |
| | | $I_O = 500\text{ mA}$ | | | 0.4 | 0.7 | |
| V_{IL} | Control input logic low | $T_a = -40\text{ to }125\text{ °C}$ | | | 0.8 | V | |
| V_{IH} | Control input logic high | $T_a = -40\text{ to }125\text{ °C}$ | 2 | | | V | |
| I_i | Control input current | $V_I = 10\text{ V}$ $V_C = 6\text{ V}$ | | | 10 | μA | |
| C_O | Output bypass capacitance | ESR = 0.1 to 10 Ω $I_O = 0\text{ to }500\text{ mA}$ | 2 | 10 | | μF | |

Refer to test circuits, $T_J = 25\text{ }^\circ\text{C}$, $C_I = 0.1\text{ }\mu\text{F}$, $C_O = 2.2\text{ }\mu\text{F}$ unless otherwise specified.

Table 28: LF120AB electrical characteristics

| Symbol | Parameter | Test condition | Min. | Typ. | Max. | Unit | |
|--------------|---------------------------|---|----------|---------------------|-------|---------------|----|
| V_O | Output voltage | $I_O = 50\text{ mA}$ $V_I = 15\text{ V}$ | 11.88 | 12 | 12.12 | V | |
| | | $I_O = 50\text{ mA}$ $V_I = 15\text{ V}$ $T_a = -25\text{ to }85\text{ }^\circ\text{C}$ | 11.76 | | 12.24 | | |
| V_I | Operating input voltage | $I_O = 500\text{ mA}$ | | | 16 | V | |
| I_O | Output current limit | | | 1 | | A | |
| ΔV_O | Line regulation | $V_I = 13\text{ to }16\text{ V}$ $I_O = 5\text{ mA}$ | | 12 | 60 | mV | |
| ΔV_O | Load regulation | $V_I = 13.3\text{ V}$ $I_O = 5\text{ to }500\text{ mA}$ | | 12 | 60 | mV | |
| I_d | Quiescent current | $V_I = 13\text{ to }16\text{ V}$ $I_O = 0\text{ mA}$ | | ON mode | 0.7 | 1.5 | mA |
| | | $V_I = 13.3\text{ to }16\text{ V}$ $I_O = 500\text{ mA}$ | | | | 12 | |
| | | $V_I = 13\text{ V}$ | OFF mode | 70 | 140 | μA | |
| SVR | Supply voltage rejection | $I_O = 5\text{ mA}$ $V_I = 14 \pm 1\text{ V}$ | | $f = 120\text{ Hz}$ | 69 | dB | |
| | | | | $f = 1\text{ kHz}$ | 64 | | |
| | | | | $f = 10\text{ kHz}$ | 54 | | |
| eN | Output noise voltage | $B = 10\text{ Hz to }100\text{ kHz}$ | | 50 | | μV | |
| V_d | Dropout voltage | $I_O = 200\text{ mA}$ | | 0.2 | 0.35 | V | |
| | | $I_O = 500\text{ mA}$ | | 0.4 | 0.7 | | |
| V_{IL} | Control input logic low | $T_a = -40\text{ to }125\text{ }^\circ\text{C}$ | | | 0.8 | V | |
| V_{IH} | Control input logic high | $T_a = -40\text{ to }125\text{ }^\circ\text{C}$ | 2 | | | V | |
| I_i | Control input current | $V_I = 13\text{ V}$ $V_C = 6\text{ V}$ | | 10 | | μA | |
| C_O | Output bypass capacitance | ESR = 0.1 to 10 Ω $I_O = 0\text{ to }500\text{ mA}$ | 2 | 10 | | μF | |

Refer to test circuits, $T_J = 25\text{ °C}$, $C_I = 0.1\text{ }\mu\text{F}$, $C_O = 2.2\text{ }\mu\text{F}$ unless otherwise specified.

Table 29: LF120C electrical characteristics

| Symbol | Parameter | Test condition | Min. | Typ. | Max. | Unit | |
|--------------|---------------------------|---|---------------------|------|-------|---------------|---------------|
| V_O | Output voltage | $I_O = 50\text{ mA}$ $V_I = 14\text{ V}$ | 11.76 | 12 | 12.24 | V | |
| | | $I_O = 50\text{ mA}$ $V_I = 14\text{ V}$ $T_a = -25\text{ to }85\text{ °C}$ | 11.52 | | 12.48 | | |
| V_I | Operating input voltage | $I_O = 500\text{ mA}$ | | | 16 | V | |
| I_O | Output current limit | | | 1 | | A | |
| ΔV_O | Line regulation | $V_I = 13\text{ to }16\text{ V}$ $I_O = 5\text{ mA}$ | | 12 | 60 | mV | |
| ΔV_O | Load regulation | $V_I = 13.3\text{ V}$ $I_O = 5\text{ to }500\text{ mA}$ | | 12 | 60 | mV | |
| I_d | Quiescent current | $V_I = 13\text{ to }16\text{ V}$ $I_O = 0\text{ mA}$ | ON mode | | 0.7 | 1.5 | mA |
| | | $V_I = 13.3\text{ to }16\text{ V}$ $I_O = 500\text{ mA}$ | | | | 12 | |
| | | $V_I = 13\text{ V}$ | OFF mode | | 70 | 140 | μA |
| SVR | Supply voltage rejection | $I_O = 5\text{ mA}$ $V_I = 14 \pm 1\text{ V}$ | $f = 120\text{ Hz}$ | | 69 | dB | |
| | | | $f = 1\text{ kHz}$ | | 64 | | |
| | | | $f = 10\text{ kHz}$ | | 54 | | |
| eN | Output noise voltage | $B = 10\text{ Hz to }100\text{ kHz}$ | | 50 | | μV | |
| V_d | Dropout voltage | $I_O = 200\text{ mA}$ | | 0.2 | 0.35 | V | |
| | | $I_O = 500\text{ mA}$ | | 0.4 | 0.7 | | |
| V_{IL} | Control input logic low | $T_a = -40\text{ to }125\text{ °C}$ | | | 0.8 | V | |
| V_{IH} | Control input logic high | $T_a = -40\text{ to }125\text{ °C}$ | 2 | | | V | |
| I_i | Control input current | $V_I = 13\text{ V}$ $V_C = 6\text{ V}$ | | 10 | | μA | |
| C_O | Output bypass capacitance | ESR = 0.1 to 10 Ω $I_O = 0\text{ to }500\text{ mA}$ | 2 | 10 | | μF | |

5 Typical performance characteristics

Figure 4: Dropout voltage vs output current

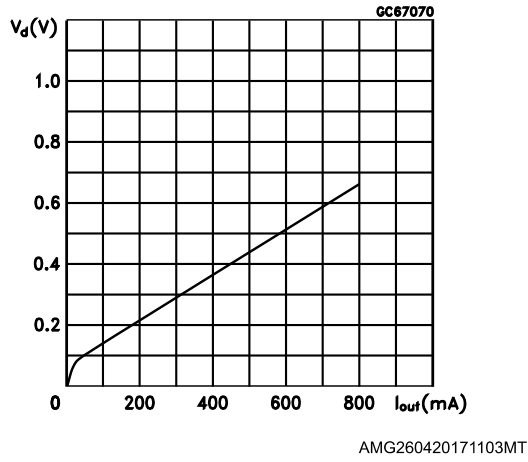

Figure 5: Dropout voltage vs temperature

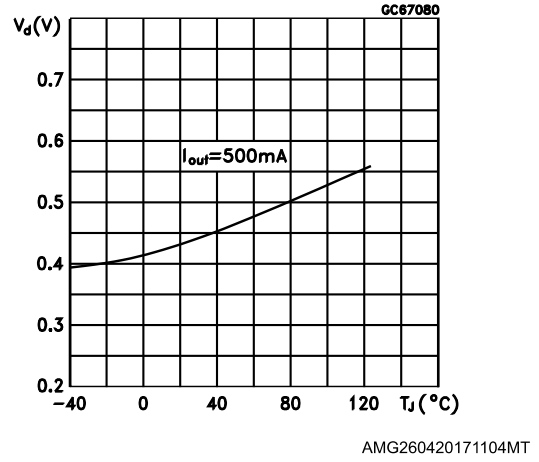

Figure 6: Supply current vs input voltage

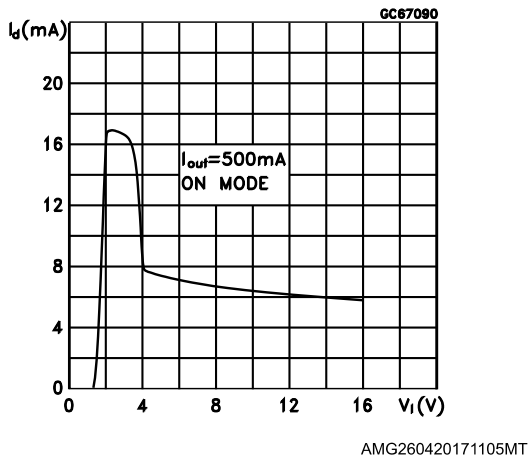
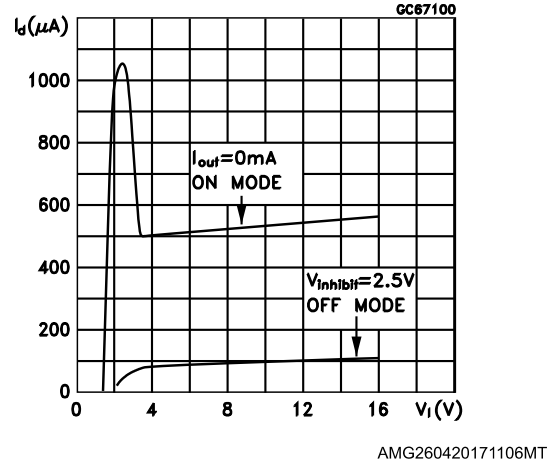
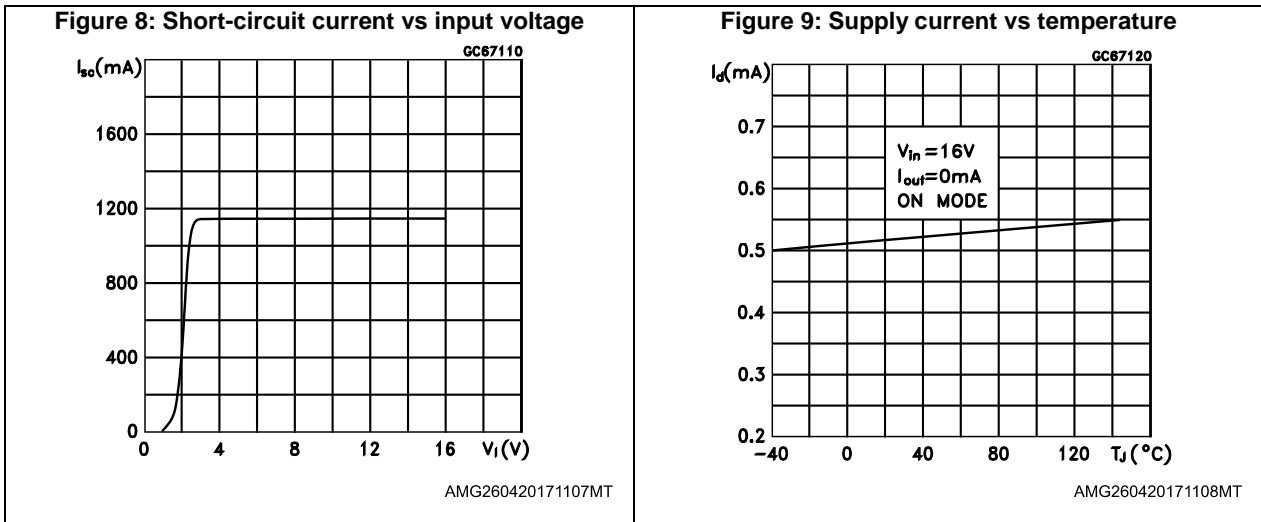

Figure 7: Supply current vs input voltage (no load)





Unless otherwise specified $V_{O(NOM)} = 3.3 V$.

Figure 10: Logic-controlled precision 3.3/5.0 V selectable output

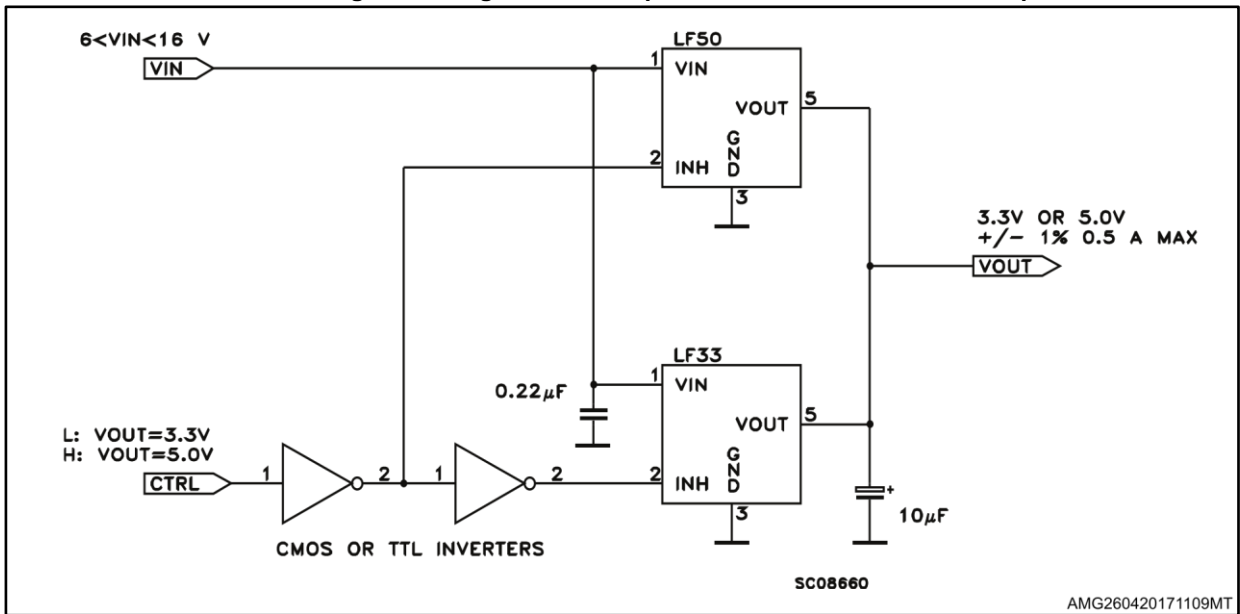

Figure 11: Sequential multi-output supply

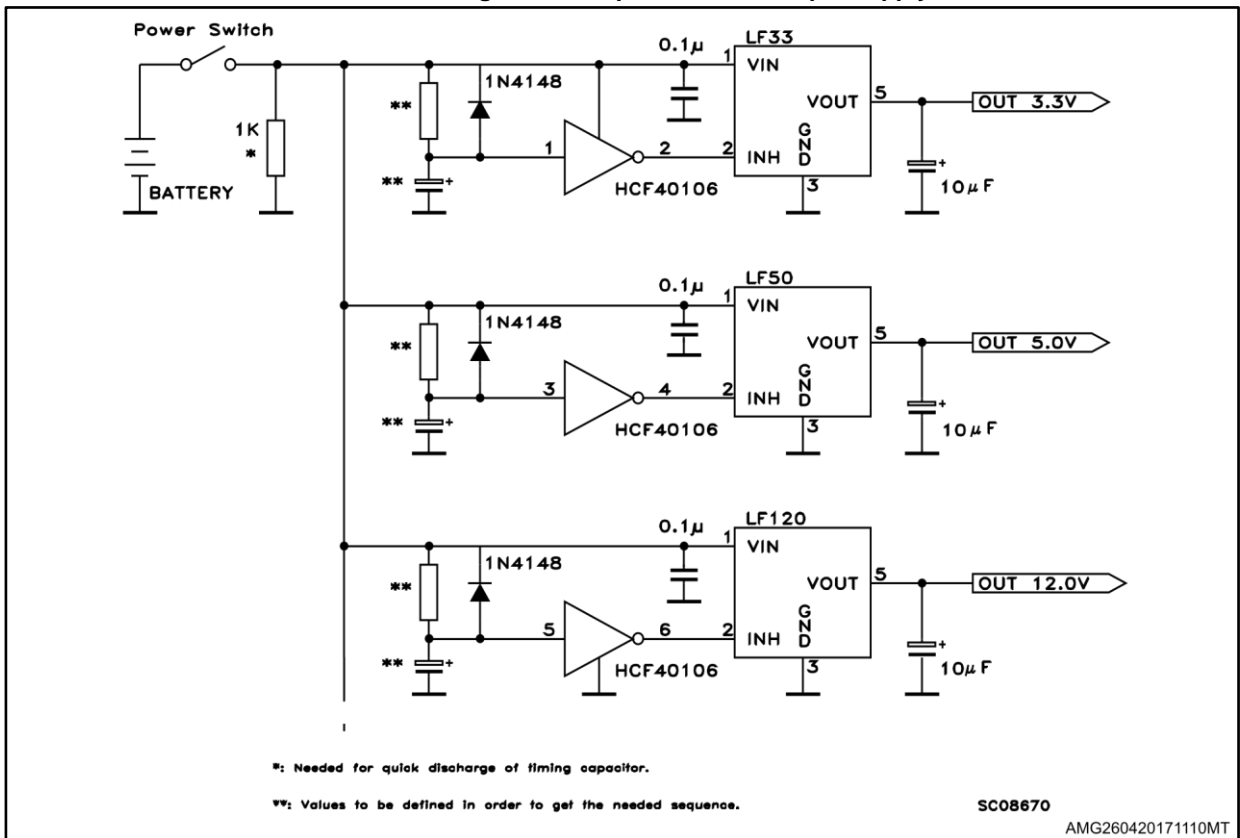

Figure 12: Multiple supply with ON/OFF toggle switch

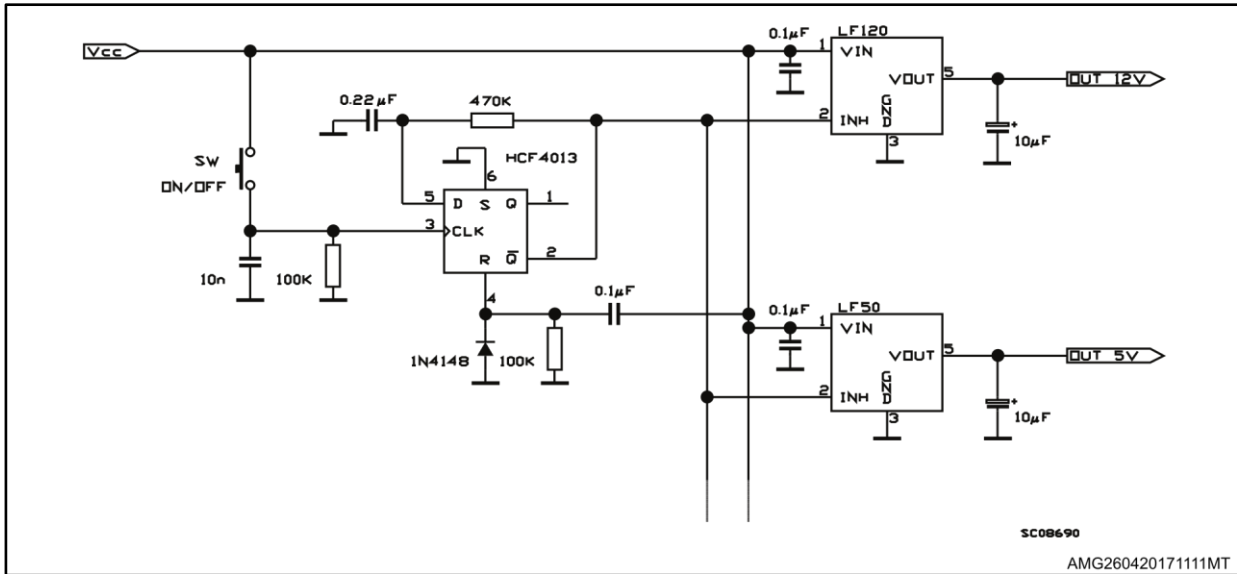

Figure 13: Basic inhibit functions

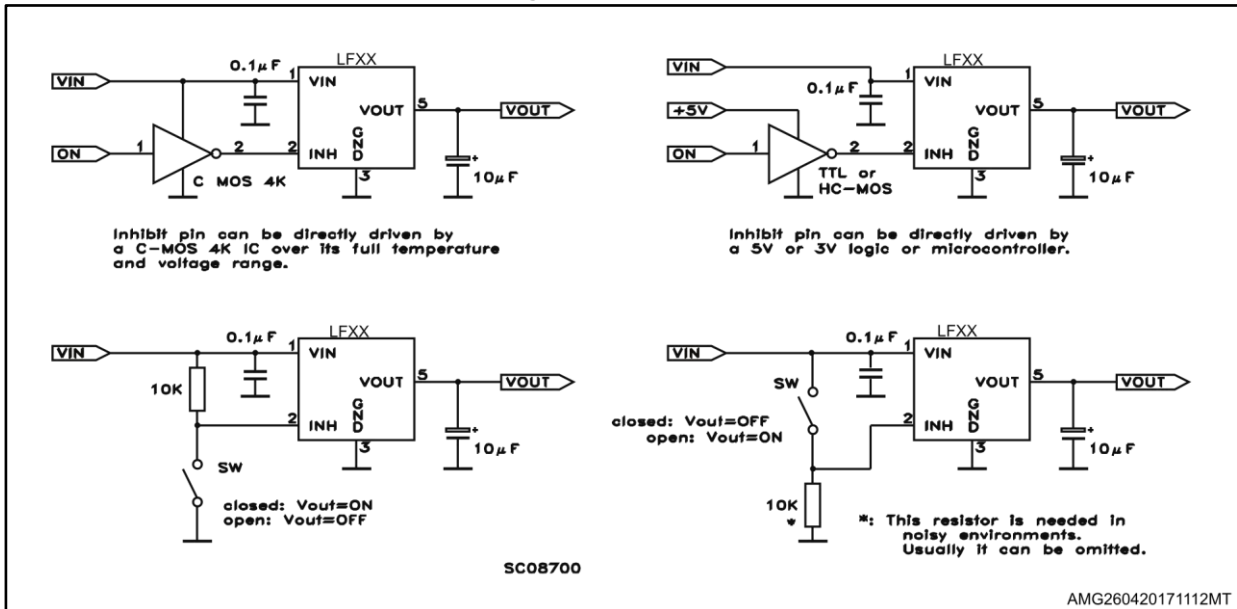

Figure 14: Delayed turn-on

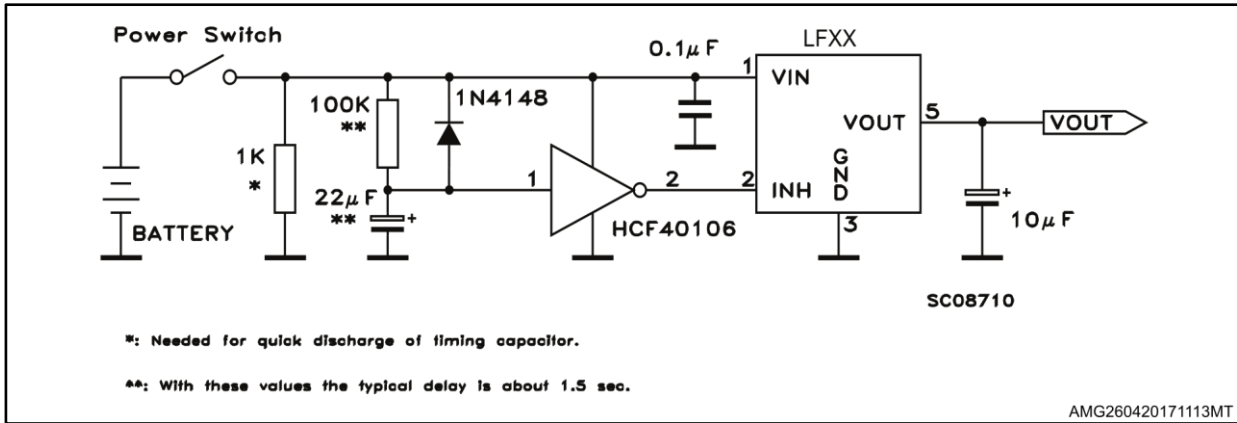
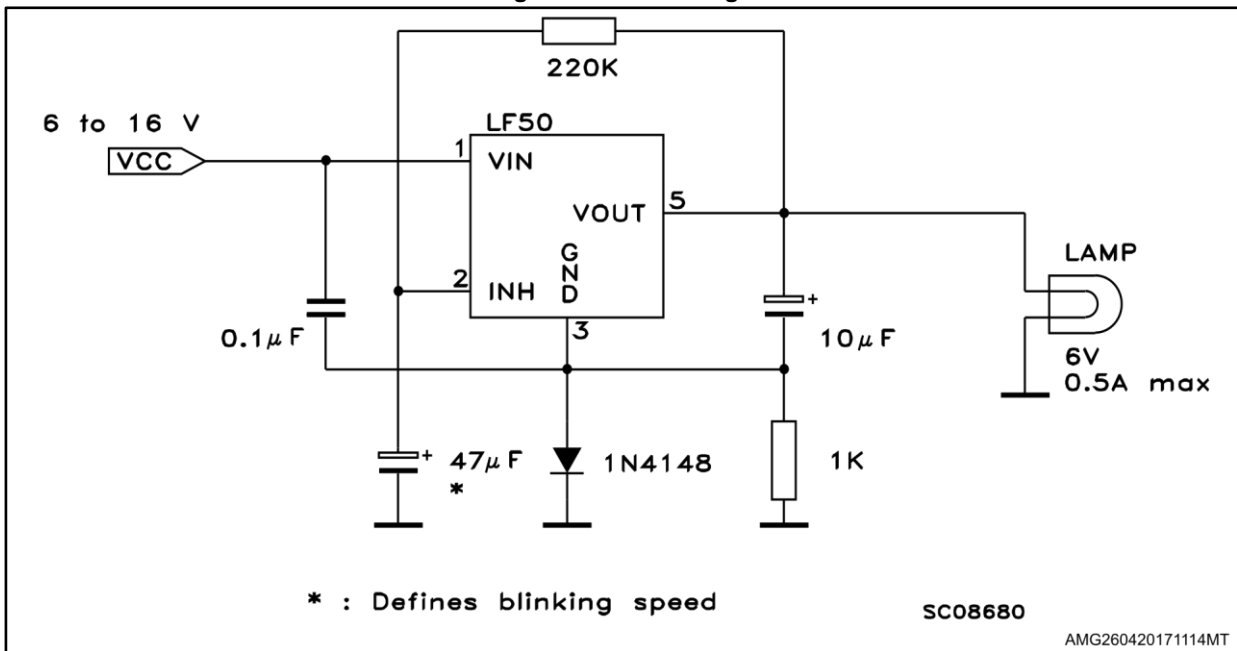

Figure 15: Low voltage bulb blinker



6 Package information

In order to meet environmental requirements, ST offers these devices in different grades of ECOPACK® packages, depending on their level of environmental compliance. ECOPACK® specifications, grade definitions and product status are available at: www.st.com. ECOPACK® is an ST trademark.

6.1 TO-220 (dual gauge) package information

Figure 16: TO-220 (dual gauge) package outline

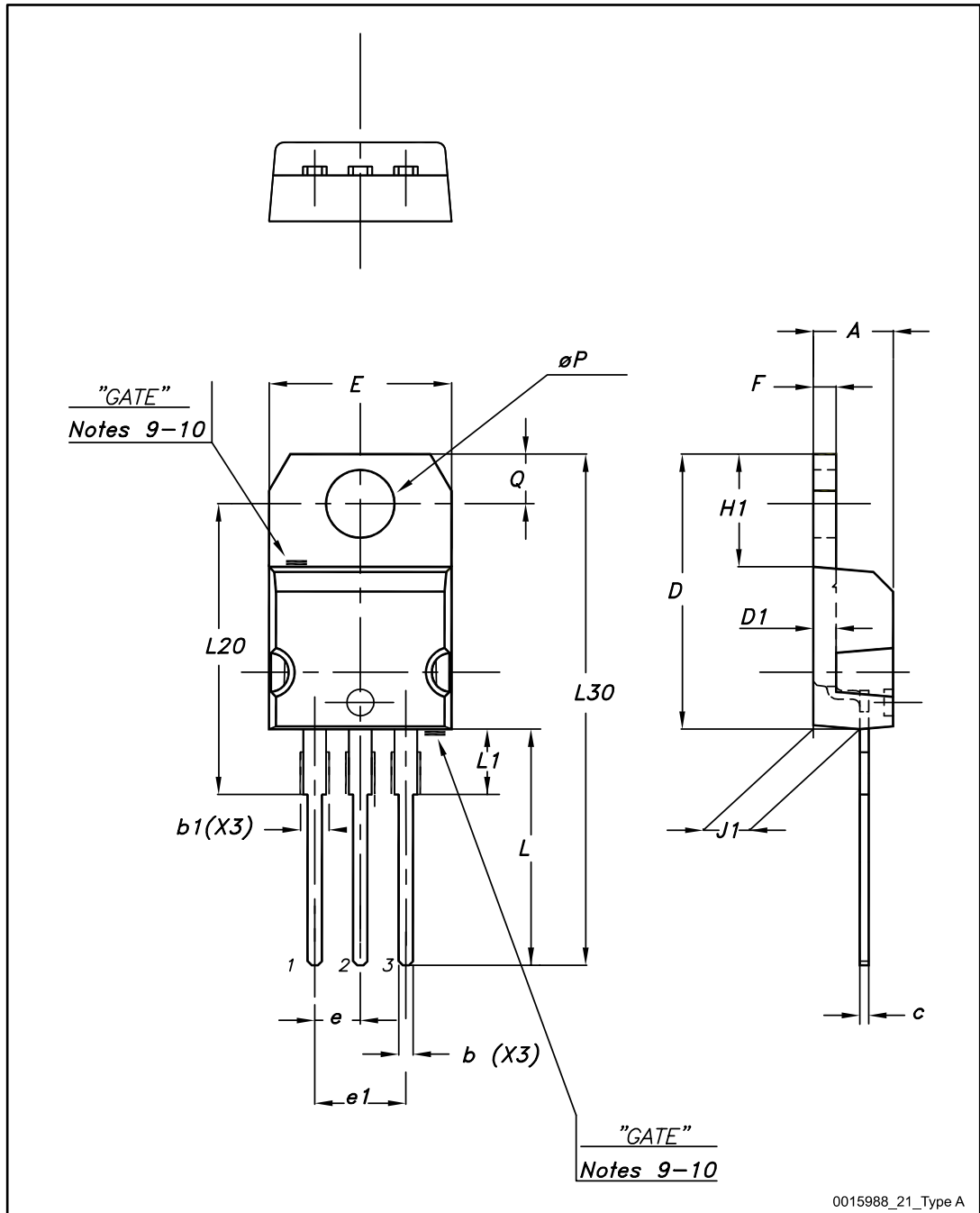

0015988_21_Type A

Table 30: TO-220 (dual gauge) mechanical data

| Dim. | mm | | |
|------|-------|-------|-------|
| | Min. | Typ. | Max. |
| A | 4.40 | | 4.60 |
| b | 0.61 | | 0.88 |
| b1 | 1.14 | | 1.70 |
| c | 0.48 | | 0.70 |
| D | 15.25 | | 15.75 |
| D1 | | 1.27 | |
| E | 10 | | 10.40 |
| e | 2.40 | | 2.70 |
| e1 | 4.95 | | 5.15 |
| F | 1.23 | | 1.32 |
| H1 | 6.20 | | 6.60 |
| J1 | 2.40 | | 2.72 |
| L | 13 | | 14 |
| L1 | 3.50 | | 3.93 |
| L20 | | 16.40 | |
| L30 | | 28.90 | |
| øP | 3.75 | | 3.85 |
| Q | 2.65 | | 2.95 |

6.2 TO-220 (single gauge) package information

Figure 17: TO-220 (single gauge) package outline

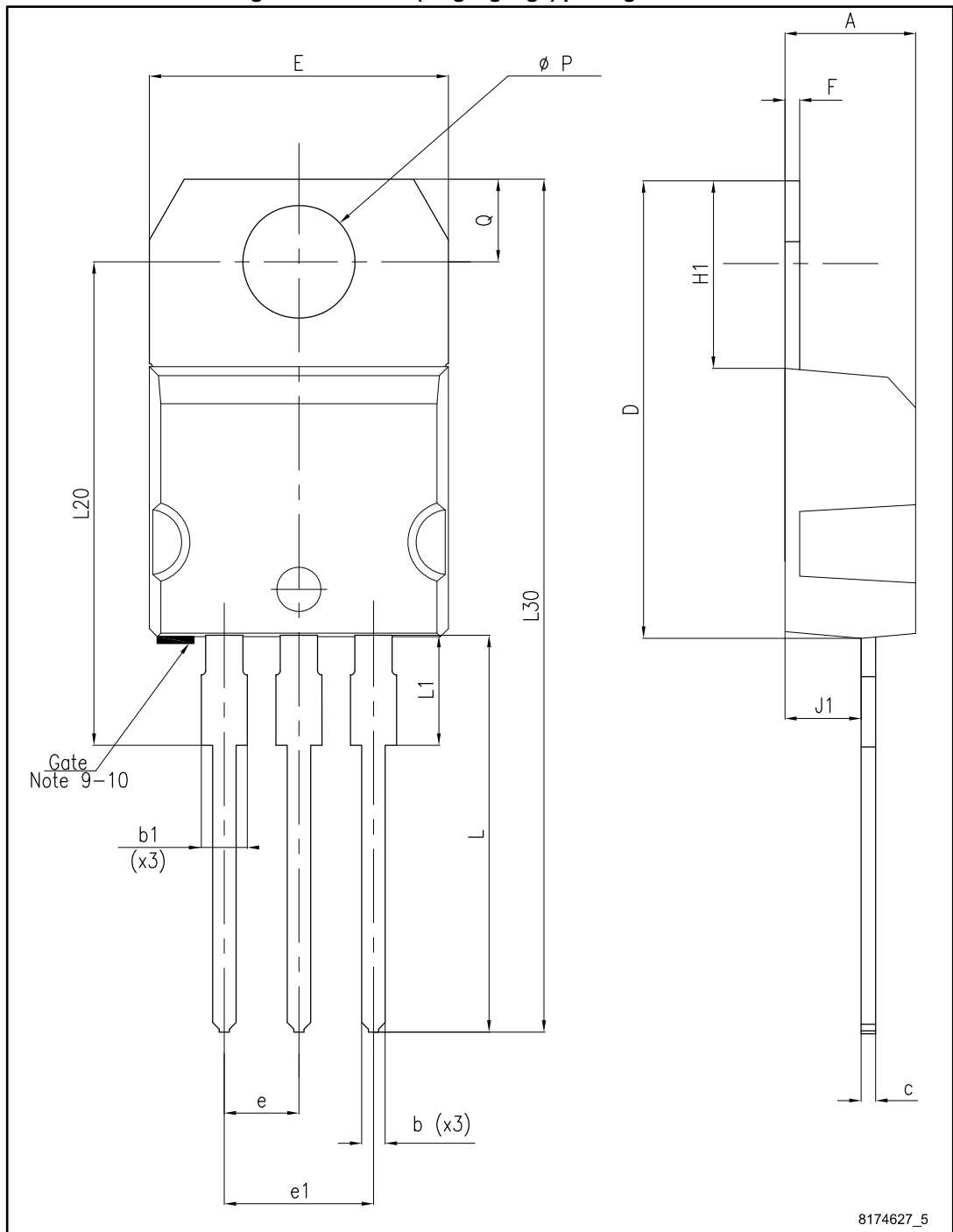

8174627_5

Table 31: TO-220 (single gauge) mechanical data

| Dim. | mm | | |
|------|-------|-------|-------|
| | Min. | Typ. | Max. |
| A | 4.40 | | 4.60 |
| b | 0.61 | | 0.88 |
| b1 | 1.14 | | 1.70 |
| c | 0.48 | | 0.70 |
| D | 15.25 | | 15.75 |
| E | 10.00 | | 10.40 |
| e | 2.40 | | 2.70 |
| e1 | 4.95 | | 5.15 |
| F | 0.51 | | 0.60 |
| H1 | 6.20 | | 6.60 |
| J1 | 2.40 | | 2.72 |
| L | 13.00 | | 14.00 |
| L1 | 3.50 | | 3.93 |
| L20 | | 16.40 | |
| L30 | | 28.90 | |
| ∅P | 3.75 | | 3.85 |
| Q | 2.65 | | 2.95 |

6.3 TO-220FP package information

Figure 18: TO-220FP package outline

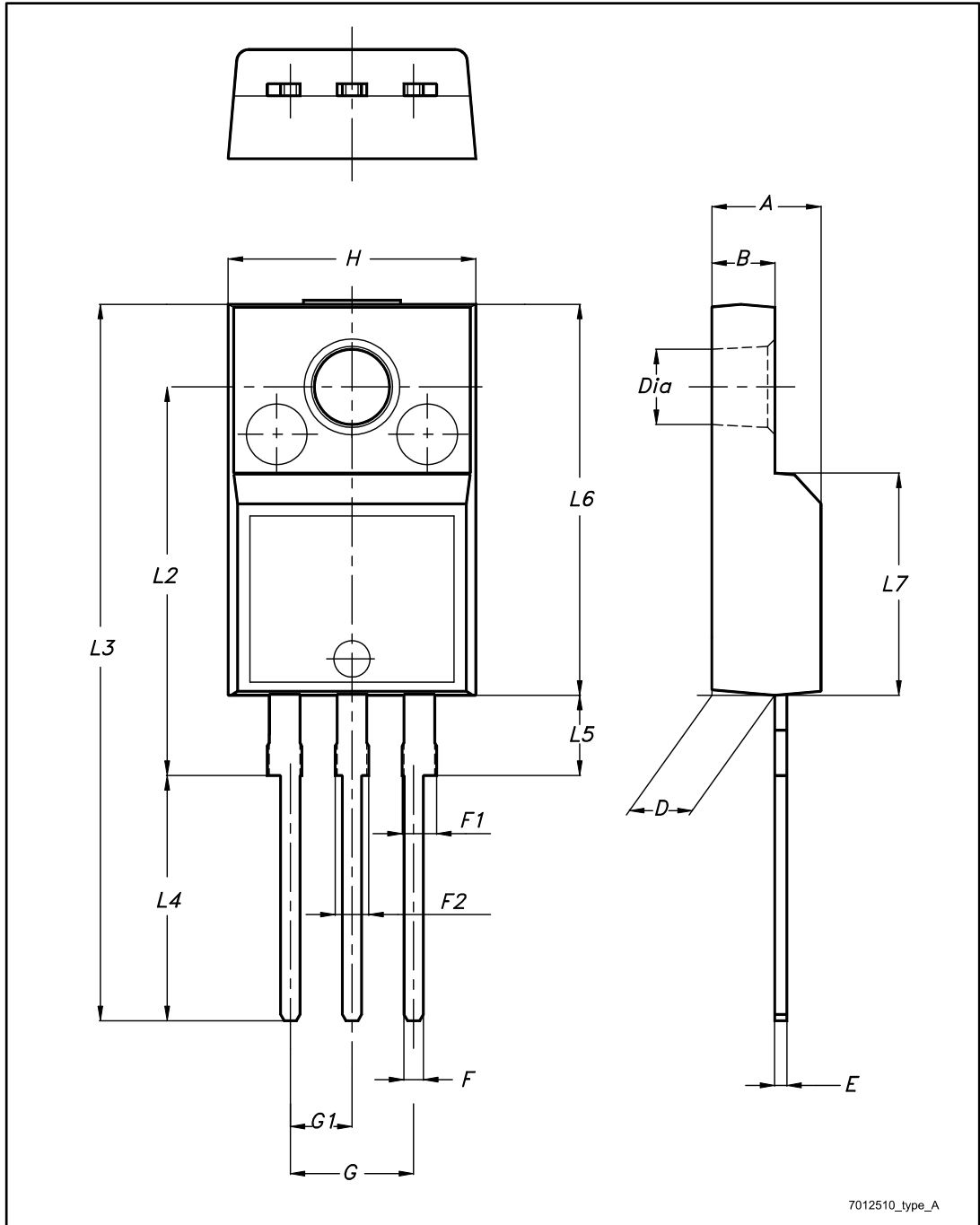

7012510_type_A

Table 32: TO-220FP package mechanical data

| Dim. | mm | | |
|------|------|------|------|
| | Min. | Typ. | Max. |
| A | 4.4 | | 4.6 |
| B | 2.5 | | 2.7 |
| D | 2.5 | | 2.75 |
| E | 0.45 | | 0.7 |
| F | 0.75 | | 1 |
| F1 | 1.15 | | 1.70 |
| F2 | 1.15 | | 1.70 |
| G | 4.95 | | 5.2 |
| G1 | 2.4 | | 2.7 |
| H | 10 | | 10.4 |
| L2 | | 16 | |
| L3 | 28.6 | | 30.6 |
| L4 | 9.8 | | 10.6 |
| L5 | 2.9 | | 3.6 |
| L6 | 15.9 | | 16.4 |
| L7 | 9 | | 9.3 |
| Dia | 3 | | 3.2 |

6.4 TO-220 packing information

Figure 19: Tube for TO-220 (dual gauge) (mm.)

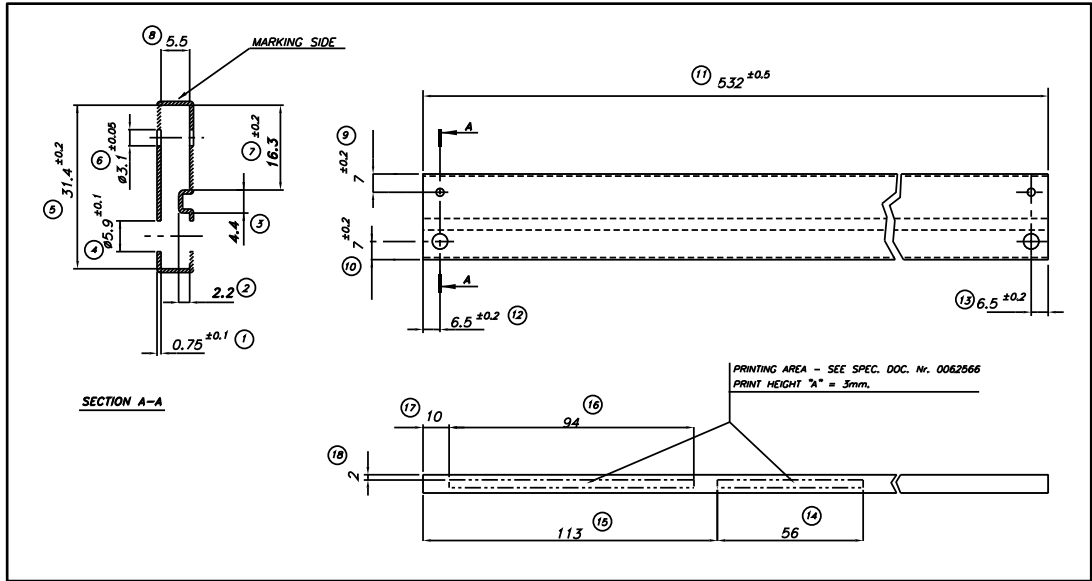
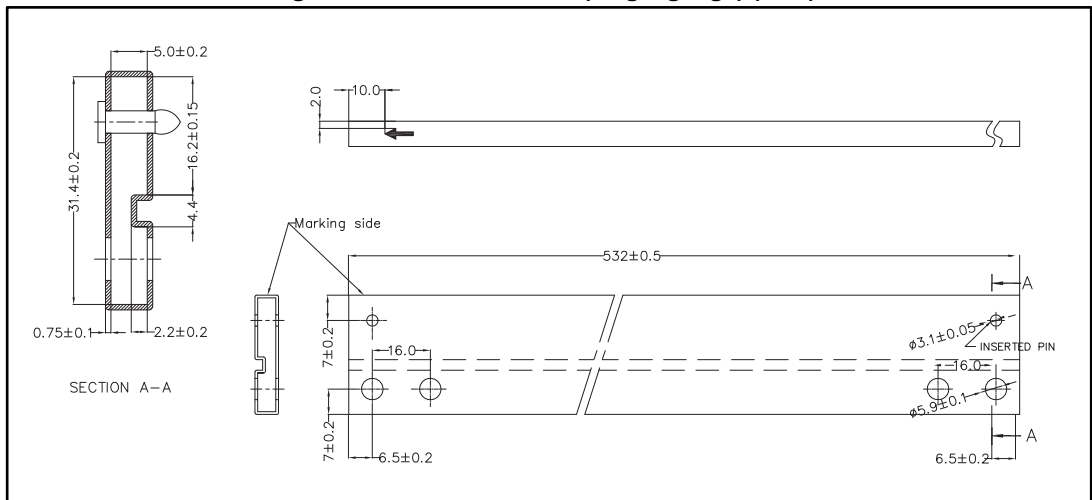

Figure 20: Tube for TO-220 (single gauge) (mm.)



6.5 DPAK package information

Figure 21: DPAK package outline

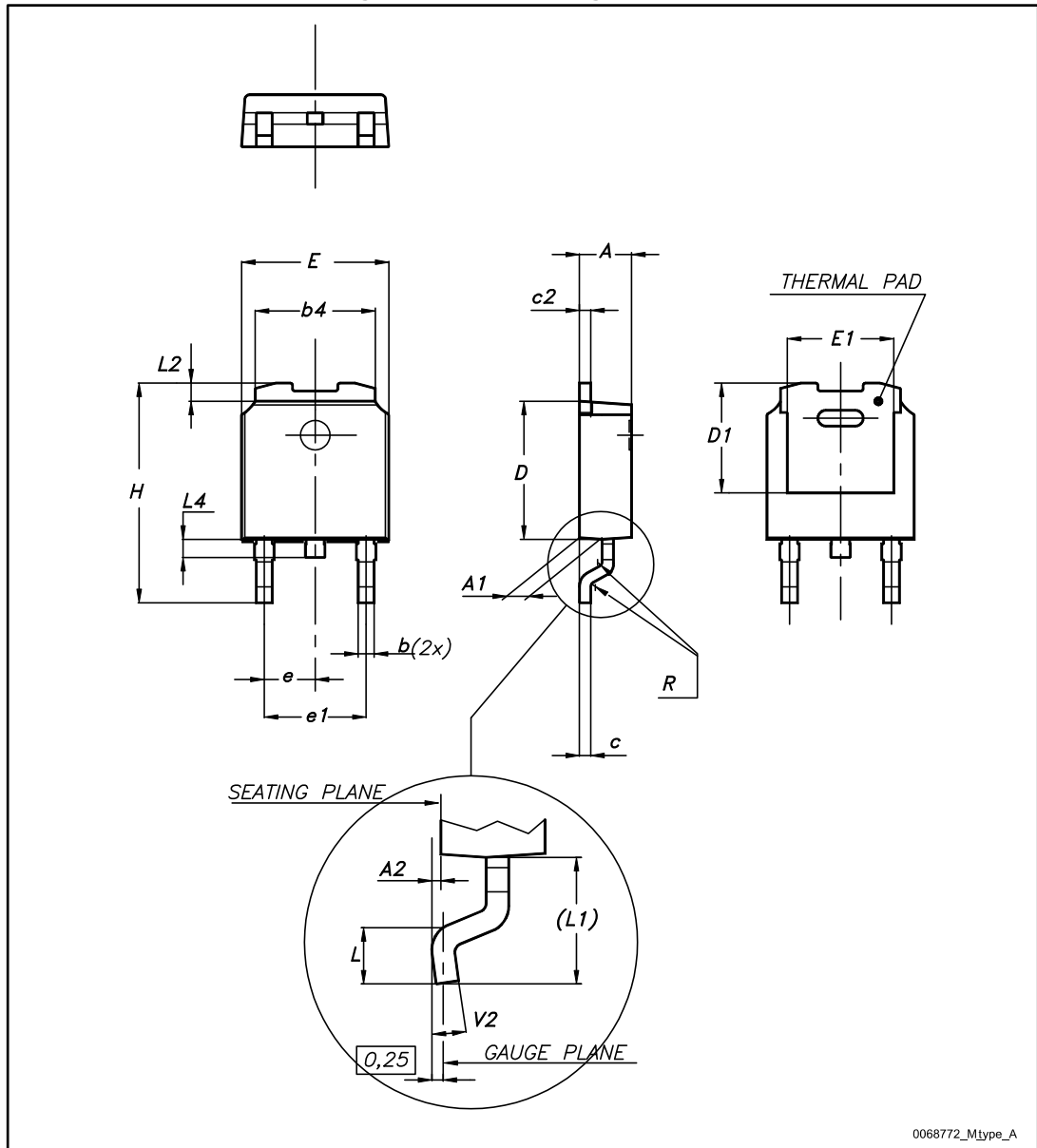
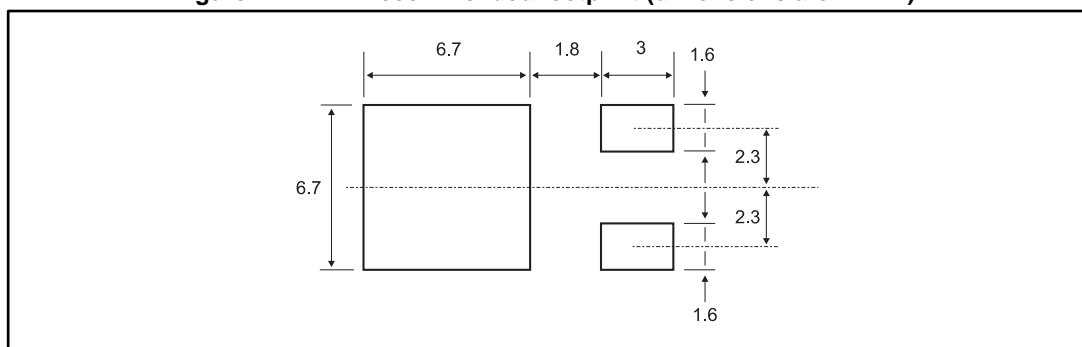

Table 33: DPAK mechanical data

| Dim. | mm | | |
|------|------|------|-------|
| | Min. | Typ. | Max. |
| A | 2.20 | | 2.40 |
| A1 | 0.90 | | 1.10 |
| A2 | 0.03 | | 0.23 |
| b | 0.64 | | 0.90 |
| b4 | 5.20 | | 5.40 |
| c | 0.45 | | 0.60 |
| c2 | 0.48 | | 0.60 |
| D | 6.00 | | 6.20 |
| D1 | | 5.10 | |
| E | 6.40 | | 6.60 |
| E1 | | 4.70 | |
| e | | 2.28 | |
| e1 | 4.40 | | 4.60 |
| H | 9.35 | | 10.10 |
| L | 1.00 | | 1.50 |
| (L1) | | 2.80 | |
| L2 | | 0.80 | |
| L4 | 0.60 | | 1.00 |
| R | | 0.20 | |
| V2 | 0° | | 8° |

Figure 22: DPAK recommended footprint (dimensions are in mm)



6.6 PPAK package information

Figure 23: PPAK package outline

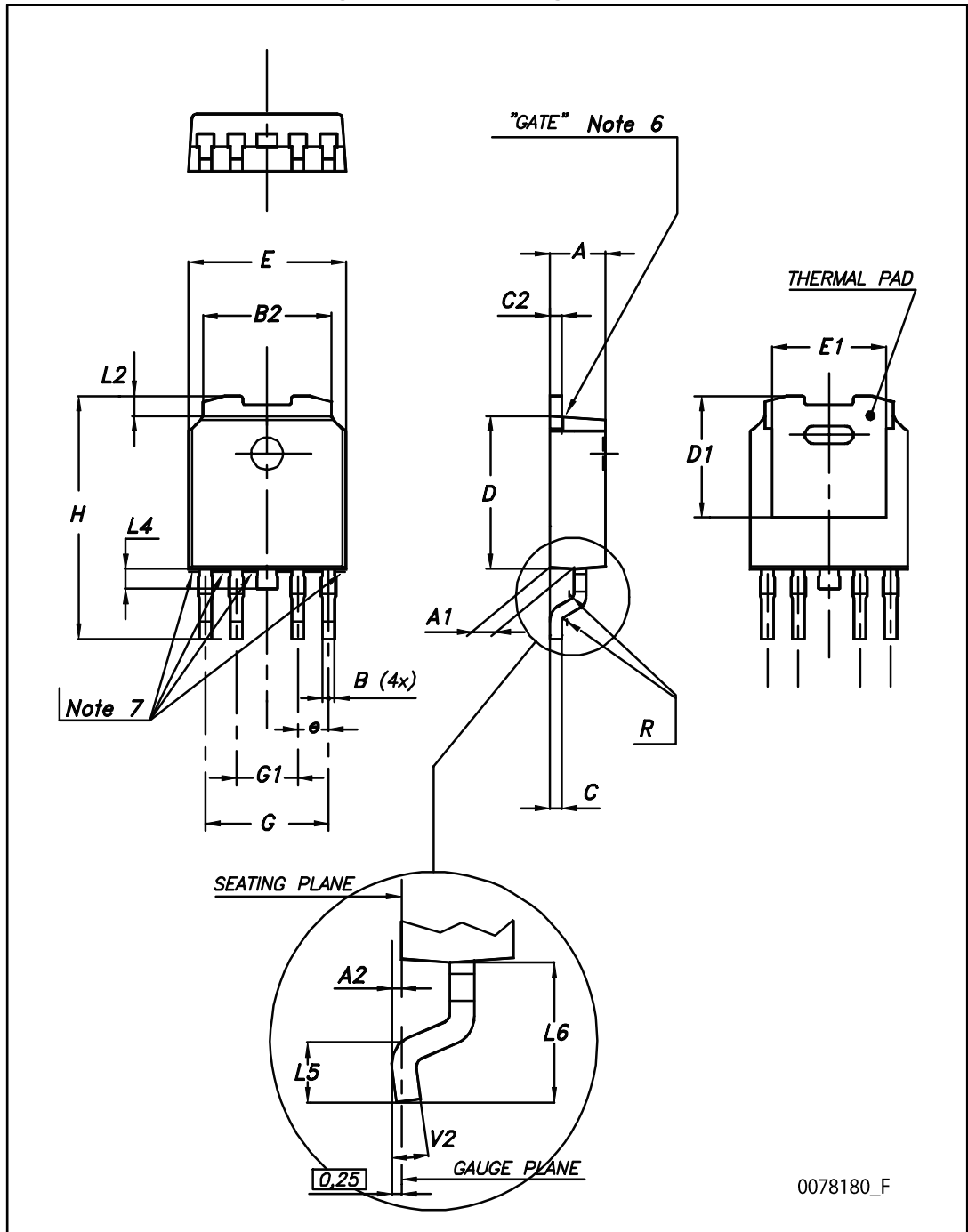

Table 34: PPAK mechanical data

| Dim. | mm | | |
|------|------|------|------|
| | Min. | Typ. | Max. |
| A | 2.2 | | 2.4 |
| A1 | 0.9 | | 1.1 |
| A2 | 0.03 | | 0.23 |
| B | 0.4 | | 0.6 |
| B2 | 5.2 | | 5.4 |
| C | 0.45 | | 0.6 |
| C2 | 0.48 | | 0.6 |
| D | 6 | | 6.2 |
| D1 | | 5.1 | |
| E | 6.4 | | 6.6 |
| E1 | | 4.7 | |
| e | | 1.27 | |
| G | 4.9 | | 5.25 |
| G1 | 2.38 | | 2.7 |
| H | 9.35 | | 10.1 |
| L2 | | 0.8 | 1 |
| L4 | 0.6 | | 1 |
| L5 | 1 | | |
| L6 | | 2.8 | |
| R | | 0.20 | |
| V2 | 0° | | 8° |

6.7 PPAK and DPAK packing information

Figure 24: PPAK and DPAK tape

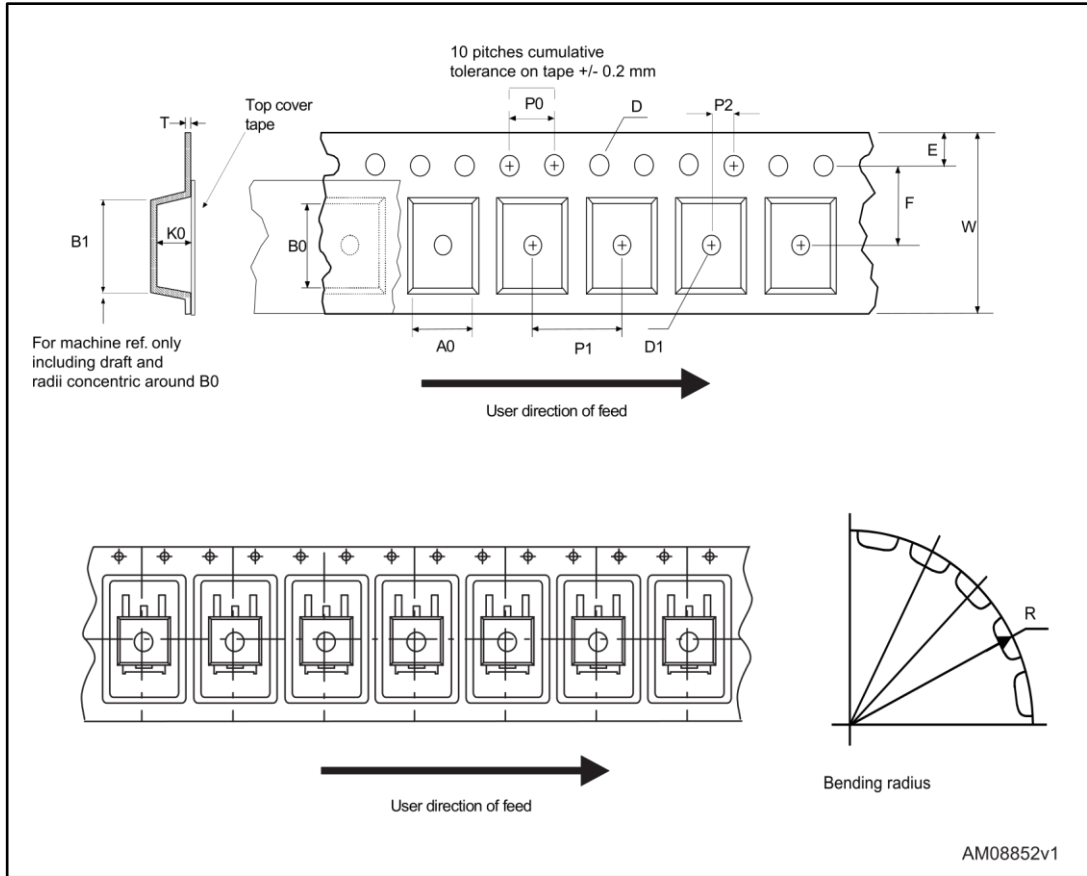

Figure 25: PPAK and DPAK reel

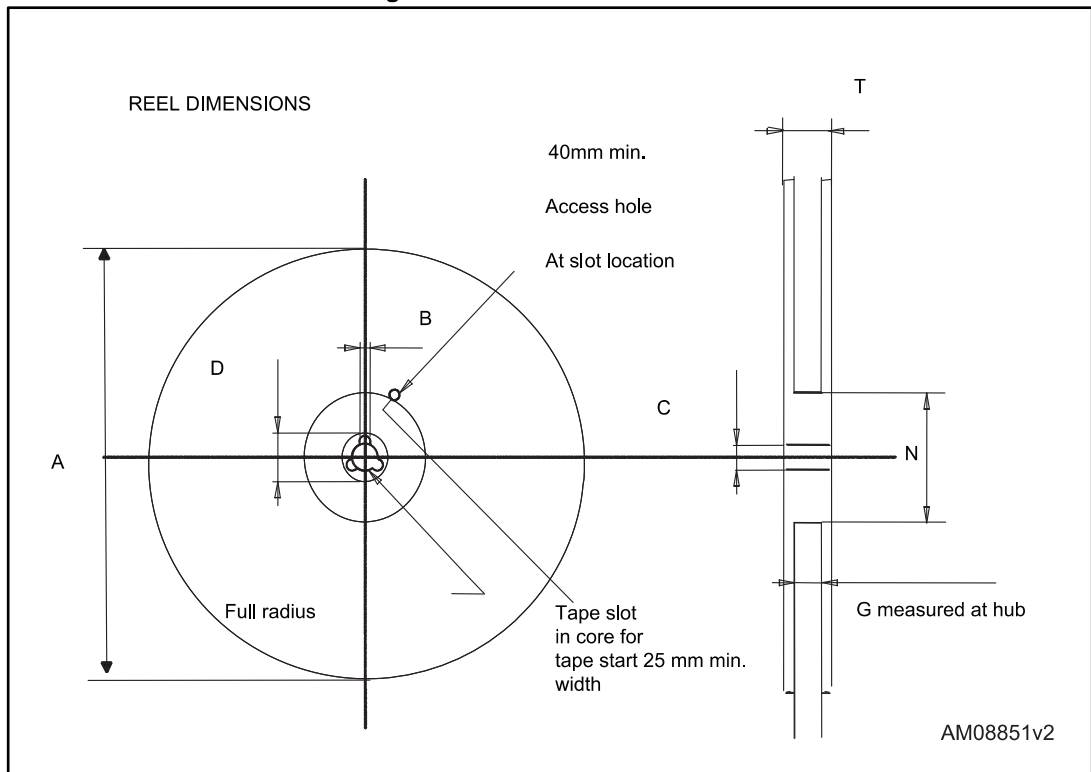

Table 35: PPAK and DPAK tape and reel mechanical data

| Tape | | | Reel | | |
|------|------|------|-----------|------|------|
| Dim. | mm | | Dim. | mm | |
| | Min. | Max. | | Min. | Max. |
| A0 | 6.8 | 7 | A | | 330 |
| B0 | 10.4 | 10.6 | B | 1.5 | |
| B1 | | 12.1 | C | 12.8 | 13.2 |
| D | 1.5 | 1.6 | D | 20.2 | |
| D1 | 1.5 | | G | 16.4 | 18.4 |
| E | 1.65 | 1.85 | N | 50 | |
| F | 7.4 | 7.6 | T | | 22.4 |
| K0 | 2.55 | 2.75 | | | |
| P0 | 3.9 | 4.1 | Base qty. | | 2500 |
| P1 | 7.9 | 8.1 | Bulk qty. | | 2500 |
| P2 | 1.9 | 2.1 | | | |
| R | 40 | | | | |
| T | 0.25 | 0.35 | | | |
| W | 15.7 | 16.3 | | | |

7 Ordering information

Table 36: Order code

| Package | | | | | Output voltage (V) |
|---------|------------------------|----------|-----------------------------|----------------------------|-----------------------|
| TO-220 | TO-220 (dual gauge) | TO-220FP | DPAK (tape and reel) | PPAK (tape and reel) | |
| | | | LF15ABDT-TR | | 1.5 |
| | | | LF18CDT-TR | LF18CPT-TR | 1.8 |
| | | | LF18CDT-TRY ⁽¹⁾ | | 1.8 |
| | | | LF18ABDT-TR | LF18ABPT-TR | 1.8 |
| | | | LF25CDT-TR | LF25CPT-TR | 2.5 |
| | | | LF25CDT-TRY ⁽¹⁾ | | 2.5 |
| | | | LF25ABDT-TR | | 2.5 |
| | | | LF25ABDT-TRY ⁽¹⁾ | | 2.5 |
| LF33CV | LF33CV-DG | | LF33CDT-TR | LF33CPT-TR | 3.3 |
| | | | LF33CDT-TRY ⁽¹⁾ | LF33CPT-TRY ⁽¹⁾ | 3.3 |
| LF33ABV | LF33ABV-DG | | LF33ABDT-TR | | 3.3 |
| LF50CV | LF50CV-DG | | LF50CDT-TR | LF50CPT-TR | 5 |
| | | | LF50CDT-TRY ⁽¹⁾ | LF50CPT-TRY ⁽¹⁾ | 5 |
| LF50ABV | LF50ABV-DG | | LF50ABDT-TR | LF50ABPT-TR | 5 |
| | | LF50ACP | | | 5 |
| | | | LF50ABDT-TRY ⁽¹⁾ | | 5 |
| LF60CV | | | LF60CDT-TR | | 6 |
| LF60ABV | | | LF60ABDT-TR | | 6 |
| | | | LF80CDT-TR | | 8 |
| | | | LF80CDT-TRY ⁽¹⁾ | | 8 |
| | | | LF80ABDT-TR | | 8 |
| | | | LF85CDT-TR | LF85CPT-TR | 8.5 |
| | | | LF85CDT-TRY ⁽¹⁾ | LF85CPT-TRY ⁽¹⁾ | 8.5 |
| LF90CV | | | | LF90CPT-TR | 9 |
| | | | LF120CDT-TR | | 12 |
| | | | LF120ABDT-TR | | 12 |

Notes:

⁽¹⁾Qualified and characterized according to AEC Q100 and Q003 or equivalent, advanced screening according to AEC Q001 and Q002 or equivalent.

8 Revision history

Table 37: Document revision history

| Date | Revision | Changes |
|-------------|----------|---|
| 21-Jun-2004 | 14 | Document updating. |
| 24-May-2006 | 15 | Order codes updated. |
| 02-Apr-2007 | 16 | Order codes updated. |
| 14-May-2007 | 17 | Order codes updated. |
| 26-Jul-2007 | 18 | Add table 1 in cover page. |
| 26-Nov-2007 | 19 | Modified: Table 34. |
| 16-Jan-2008 | 20 | Added new order codes for automotive grade products see Table 34 on page 51. |
| 12-Feb-2008 | 21 | Modified: Table 34 on page 51. |
| 10-Jul-2008 | 22 | Modified: Table 34 on page 51. |
| 05-May-2010 | 23 | Added: Table 29 on page 41, fig 16, fig 17, fig 18 and fig 19. |
| 16-Nov-2010 | 24 | Modified: R_{thJC} value for TO-220 Table 2 on page 7. |
| 10-Feb-2012 | 25 | Added: order code LF33CV-DG and LF33ABV-DG Table 34 on page 51. |
| 09-Mar-2012 | 26 | Added: order code LF50ABV-DG Table 34 on page 51. |
| 28-Feb-2014 | 27 | <p>Changed the part numbers LFxxAB and LFxxC to LFXX.</p> <p>Changed the title.</p> <p>Removed table from cover page.</p> <p>Removed PENTAWATT package from the figure in cover page, the Description and Figure 2.</p> <p>Updated the Description.</p> <p>Updated: Table 2, Table 6, Table 8, Table 10, Table 13, Table 15, Table 17, Table 22, Table 25 and Table 34.</p> <p>Changed title of Figure 7.</p> <p>Updated mechanical data.</p> |
| 03-Mar-2015 | 28 | <p>Updated Table 34: Order code.</p> <p>Minor text changes.</p> |
| 19-Jan-2017 | 29 | <p>Updated output voltage values in Table 16 and added new commercial type in TO-220FP in Table 35.</p> <p>Minor text changes.</p> |
| 27-Jan-2017 | 30 | Updated features in cover page. Added Table 14 and updated Table 35. |
| 22-May-2017 | 31 | <p>Updated Table 36: "Order code".</p> <p>Minor text changes.</p> |

IMPORTANT NOTICE – PLEASE READ CAREFULLY

STMicroelectronics NV and its subsidiaries ("ST") reserve the right to make changes, corrections, enhancements, modifications, and improvements to ST products and/or to this document at any time without notice. Purchasers should obtain the latest relevant information on ST products before placing orders. ST products are sold pursuant to ST's terms and conditions of sale in place at the time of order acknowledgement.

Purchasers are solely responsible for the choice, selection, and use of ST products and ST assumes no liability for application assistance or the design of Purchasers' products.

No license, express or implied, to any intellectual property right is granted by ST herein.

Resale of ST products with provisions different from the information set forth herein shall void any warranty granted by ST for such product.

ST and the ST logo are trademarks of ST. All other product or service names are the property of their respective owners.

Information in this document supersedes and replaces information previously supplied in any prior versions of this document.

© 2017 STMicroelectronics – All rights reserved